

## Super Fast Recovery Rectifiers

Reverse Voltage - 50 to 600 V

Forward Current - 20 A

### FEATURES

- ◆The plastic package carries Underwriters Laboratory Flammability Classification 94V-0
- ◆Construction utilizes void-free molded plastic technique
- ◆Low reverse leakage
- ◆High forward surge current capability
- ◆High temperature soldering guaranteed  
260°C/10 seconds at terminals

### MECHANICAL DATA

- ◆Case: TO-220AC
- ◆Terminals: Solder plated, solderable per MIL-STD-750, Method 2026
- ◆Polarity : Polarity symbol marking on body
- ◆Mounting Position : Any

### Maximum Ratings and Electrical characteristics

Ratings at 25 °C ambient temperature unless otherwise specified.

Single phase half-wave 60 Hz, resistive or inductive load, for capacitive load current derate by 20 %.

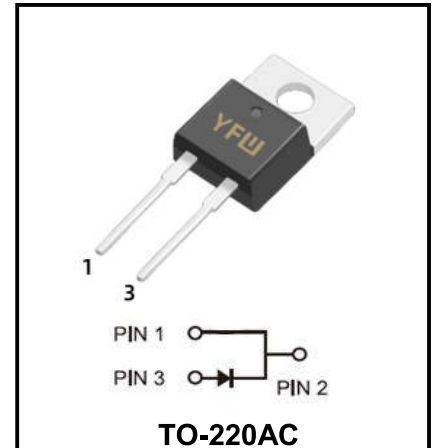

Parameter	Symbols	MUR2005DA	MUR2010DA	MUR2020DA	MUR2040DA	MUR2050DA	MUR2060DA	Units
Maximum Repetitive Peak Reverse Voltage	$V_{RRM}$	50	100	200	400	500	600	V
Maximum RMS voltage	$V_{RMS}$	35	70	140	280	350	420	V
Maximum DC Blocking Voltage	$V_{DC}$	50	100	200	400	500	600	V
Maximum Average Forward Rectified Current at $T_c = 110\text{ }^\circ\text{C}$	$I_{(AV)}$	20.0						A
Peak Forward Surge Current 8.3 ms Single Half Sine Wave Superimposed on Rated Load	$I_{FSM}$	300						A
Maximum Instantaneous Forward Voltage at 20A	$V_F$	1.0		1.5		2.5		V
Maximum DC Reverse Current $T_a = 25\text{ }^\circ\text{C}$ at Rated DC Blocking Voltage $T_a = 125\text{ }^\circ\text{C}$	$I_R$	10 500						$\mu\text{A}$
Maximum reverse recovery time	$T_{rr}$	35			50			nS
Typical Thermal Resistance	$R_{\theta JC}$	3.5						$^\circ\text{C/W}$
Operating junction temperature range	$T_j$	-55 ~ +150						$^\circ\text{C}$
Storage temperature range	$T_{stg}$	-55 ~ +150						$^\circ\text{C}$

Note:1.Reverse recovery time test condition:  $I_F=0.5\text{A}$   $I_R=1.0\text{A}$   $I_{rr}=0.25\text{A}$

**Ratings And Characteristic Curves**

**FIG. 1- DERATING CURVE OUTPUT RECTIFIED CURRENT**

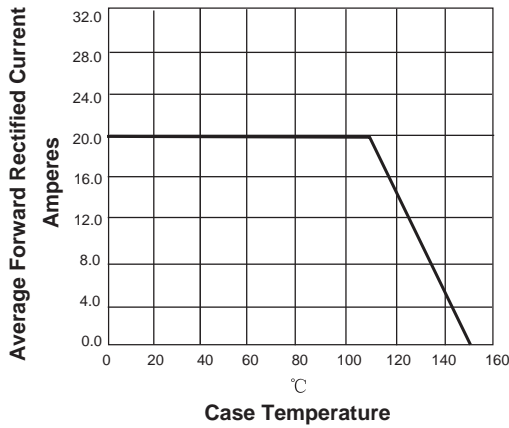

**FIG. 2-MAXIMUM NON-REPETITIVE PEAK FORWARD SURGE CURRENT PER LEG**

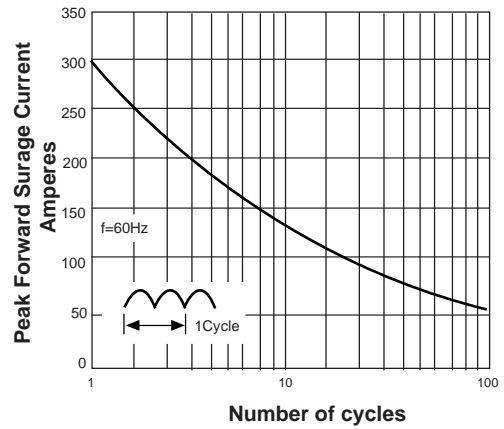

**FIG. 3-TYPICAL FORWARD VOLTAGE CHARACTERISTICS**

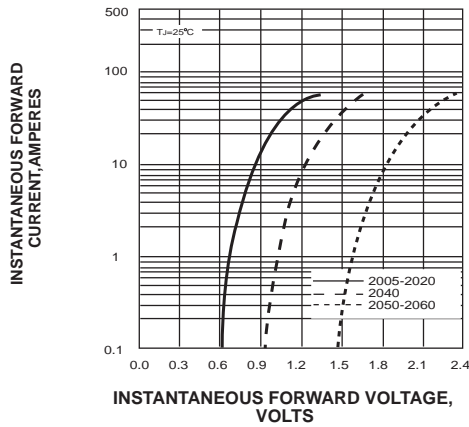

**FIG. 4-TYPICAL REVERSE LEAKAGE CHARACTERISTICS**

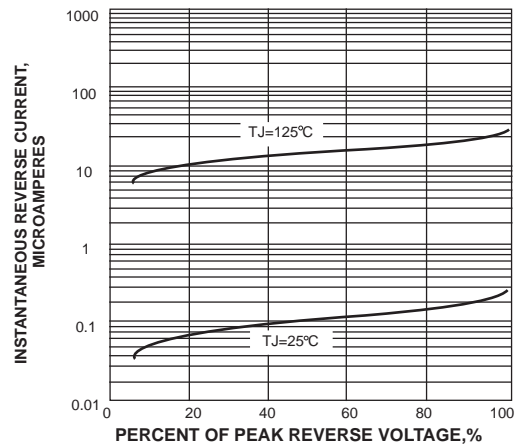

**Marking Diagram**

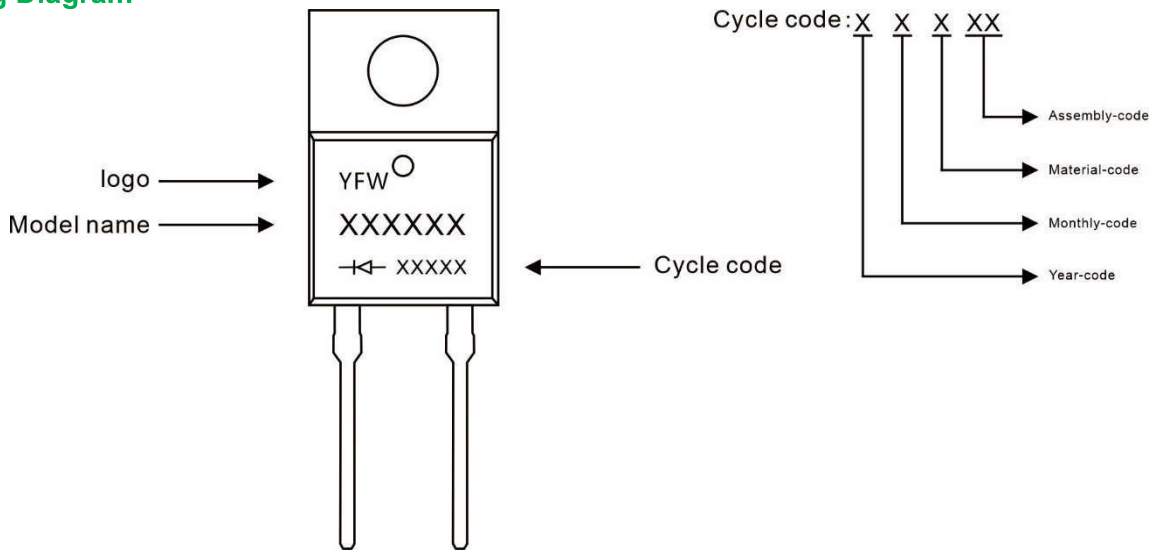

**Ordering information**

Model name	Package	Unit Weight	Base Quantity	Packing Quantity
MUR20XXDA	TO-220AC	0.067oz(1.9g)	50pcs/tube	1000PCS/Box 5000PCS/Carton

**Package Dimensions**

**TO-220AC**

Dim	Millimeter		Inches	
	Min.	Max.	Min.	Max.
A	4.34	4.67	0.171	0.184
A1	2.52	2.82	0.099	0.111
b	0.71	0.91	0.028	0.036
b1	1.17	1.37	0.046	0.054
c	0.30	0.50	0.012	0.020
c1	1.17	1.37	0.046	0.054
D	9.90	10.20	0.390	0.402
E	8.50	8.90	0.335	0.350
E1	12.00	12.50	0.472	0.492
e	2.44	2.64	0.096	0.104
e1	4.88	5.28	0.192	0.208
F	2.60	2.80	0.102	0.110
L	13.20	13.80	0.520	0.543
L1	3.80	4.20	0.150	0.165
Φ	3.60	3.96	0.142	0.156

## Disclaimer

The information presented in this document is for reference only. GuangDong Youfeng Microelectronics Co.,Ltd. reserves the right to make changes without notice for the specification of the products displayed herein to improve reliability, function or design or otherwise. The product listed herein is designed to be used with ordinary electronic equipment or devices, and not designed to be used with equipment or devices which require high level of reliability and the malfunction of which would directly endanger human life (such as medical instruments, transportation equipment, aerospace machinery, nuclear-reactor controllers, fuel controllers and other safety devices), YFW or anyone on its behalf, assumes no responsibility or liability for any damages resulting from such improper use of sale. This publication supersedes & replaces all information previously supplied. For additional information, please visit our website <https://www.yfwdiode.com>, or consult YFW sales office for further assistance.