

1.0A 4Quadrants TRIACs

Product Summary

Symbol	Value	Unit
$I_{T(AV)}$	1.0	A
$V_{DRM} V_{RRM}$	600/800	V
V_{TM}	1.55	V

Features

With high ability to withstand the shock loading of large current, With high commutation performances, 4 quadrants products especially recommended for use on inductive load.

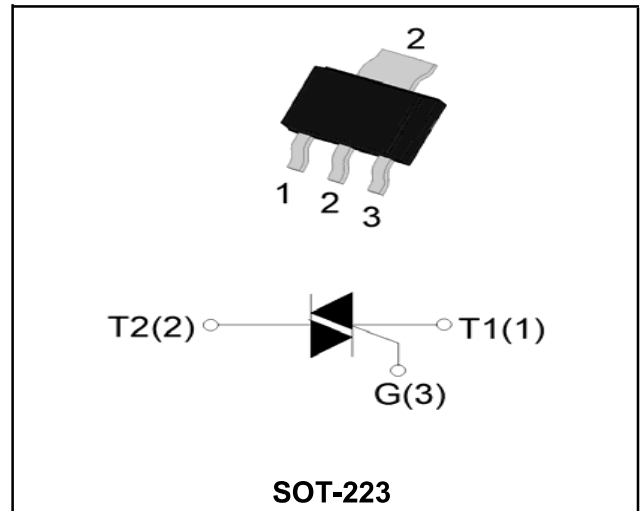

Application

Washing machine, vacuums, massager, solid state relay, AC Motor speed regulation and so on.

Absolute maximum ratings (Ta=25°C unless otherwise noted)

Parameter	Symbol	Value	Unit
Repetitive peak off-state voltage	V_{DRM}	600/800	V
Repetitive peak reverse voltage	V_{RRM}	600/800	V
RMS on-state current	$I_{T(RMS)}$	1	A
Non repetitive surge peak on-state current (full cycle, F=50Hz)	I_{TSM}	16	A
I^2t value for fusing (tp=10ms)	I^2t	1.28	A ² s
Critical rate of rise of on-state current ($I_G = 2 \times I_{GT}$)	di/dt	I - II - III	50
		IV	10
Peak gate current	I_{GM}	2	A
Average gate power dissipation	$P_G (AV)$	0.5	W
Junction Temperature	T_J	-40 ~+125	°C
Storage Temperature	T_{STG}	-40 ~+150	°C

Electrical characteristics (TA=25°C, unless otherwise noted)

Parameter	Symbol	Test Condition	Value		Unit	
			D	E		
Gate trigger current	I_{GT}	$V_D=12V$ $I_T=0.1A$ $T_j=25^\circ C$	I - II - III	3	5	mA
			IV	5	10	
Gate trigger voltage	V_{GT}	I - II - III - IV	-	1.3	V	
Gate non-trigger voltage	V_{GD}	$V_D = V_{DRM}$ $T_j=125^\circ C$	0.2	-	V	
Latching current	I_L	$V_D = 12V$ $I_{GT}=0.1A$ $T_j=25^\circ C$	I - III - IV	-	10	mA
			II	-	15	
Holding current	I_H	I - II - III - IV	-	5	mA	
Critical-rate of rise of commutation voltage	dV_D/dt	$V_D=2/3V_{DRM}$ Gate Open $T_j=125^\circ C$	50	-	V/us	

STATIC CHARACTERISTICS

Forward "on" voltage	V_{TM}	$I_{TM} = 1.5A$ $t_p=380ps$	-	1.55	V	
Repetitive Peak Off-State Current	I_{DRM}	$V_D=V_{DRM}$ $V_R=V_{RRM}$	$T_j=25^\circ C$	-	5	uA
Repetitive Peak Reverse Current	I_{RRM}		$T_j=125^\circ C$	-	100	uA

THERMAL RESISTANCES

Thermal resistance	$R_{th(j-c)}$	Junction to case(AC)	TYP.	23	°C/W
	$R_{th(j-a)}$	Junction to ambient	TYP.	60	°C/W

Ordering Information

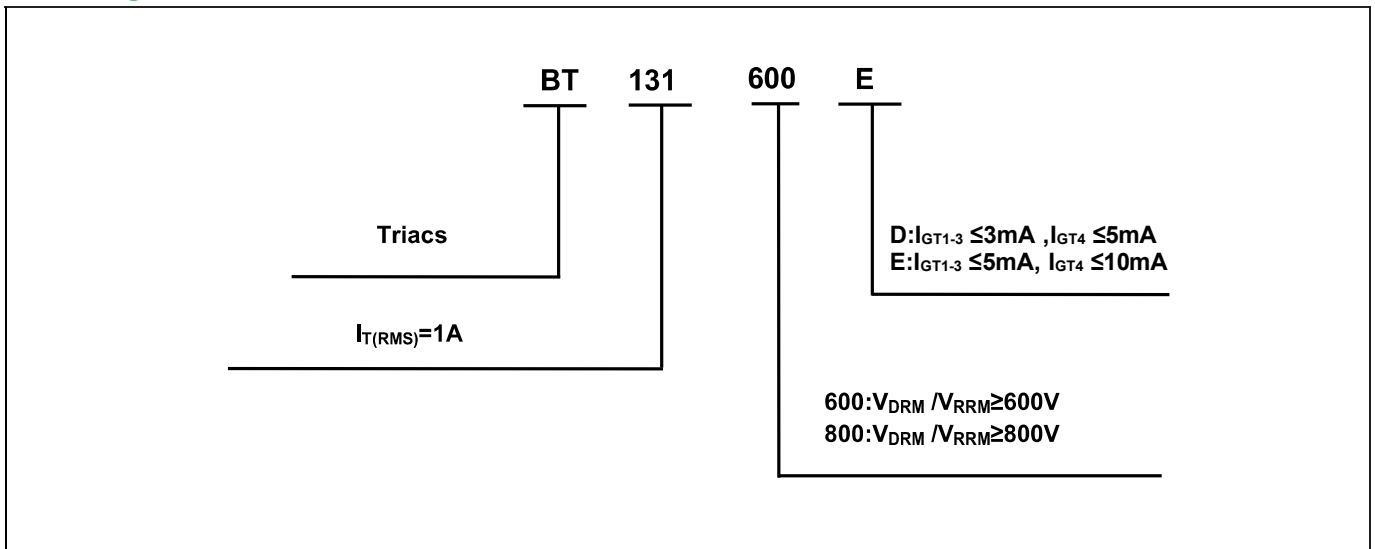

Typical Characteristics

FIG.1: Maximum power dissipation versus RMS on-state current (full cycle)

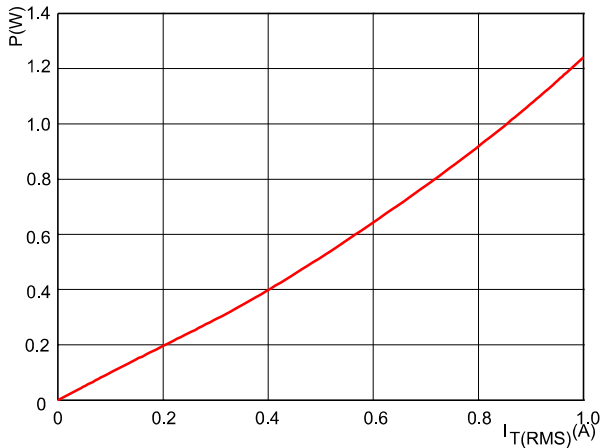

FIG.2: RMS on-state current versus case temperature (full cycle)

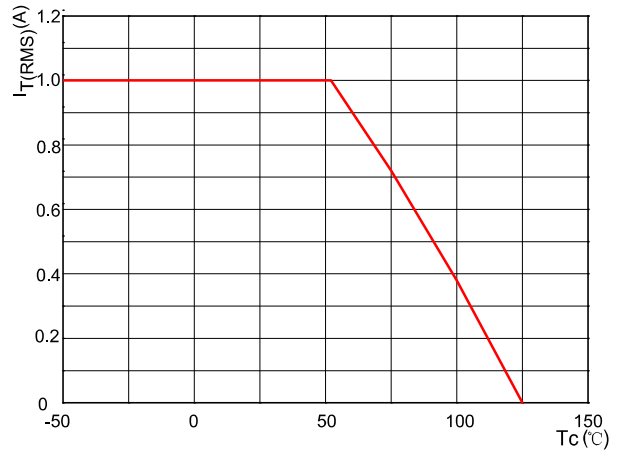

FIG.3: Surge peak on-state current versus number of cycles

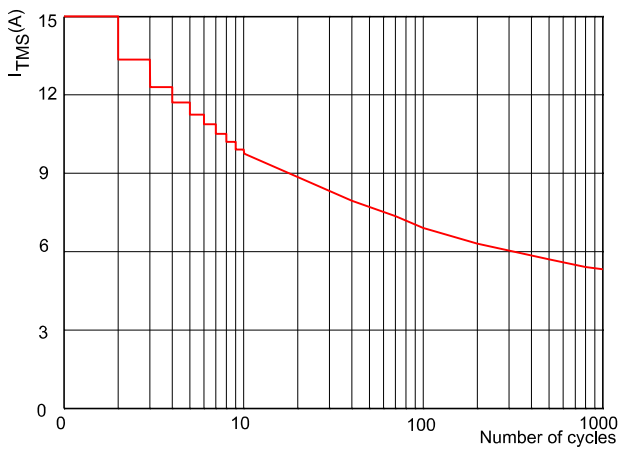

FIG.4: On-state characteristics (maximum values)

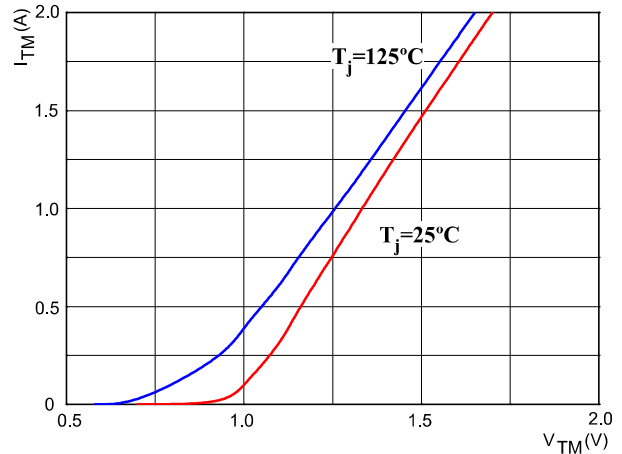

FIG.5: Non-repetitive surge peak on-state current for a sinusoidal pulse with width $t_p < 10\text{ms}$

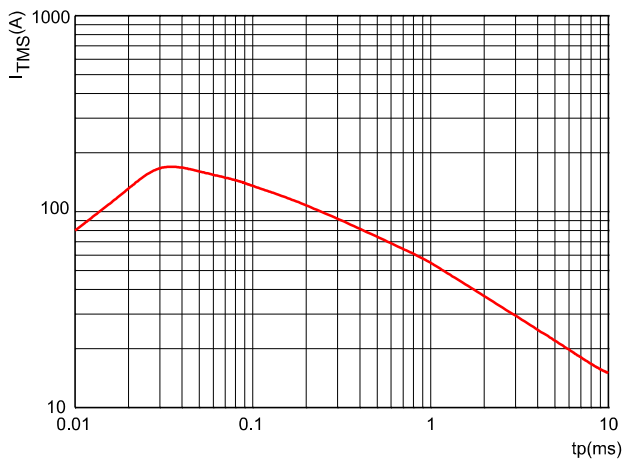
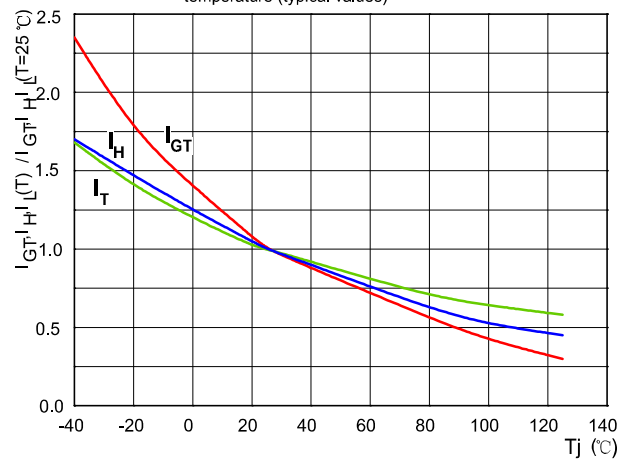

FIG.6: Relative variations of gate trigger current, holding current and latching current versus junction temperature (typical values)



Ordering information

Package	Packing Description	Base Quantity	Packing Quantity
SOT-223	Tape/Reel,7"reel	1000pcs/Reel	6000PCS/Box 30000PCS/Carton
	Tape/Reel,13"reel	2500pcs/Reel	5000PCS/Box 30000PCS/Carton

Package Dimensions

SOT-223

Dlm	Millimeter		Inches	
	Min.	Max.	Min.	Max.
A	1.50	1.80	0.059	0.071
A1	0.00	0.10	0.000	0.004
A2	1.50	1.70	0.059	0.067
b	0.65	0.75	0.026	0.030
c	0.20	0.30	0.008	0.012
D	6.40	6.60	0.252	0.260
D1	2.90	3.10	0.114	0.122
E	3.30	3.70	0.130	0.146
E1	6.85	7.15	0.270	0.281
e	2.20	2.40	0.087	0.094
e1	4.40	4.80	0.173	0.189
L	1.65	1.85	0.065	0.073
L1	0.90	1.15	0.035	0.045

The recommended mounting pad size

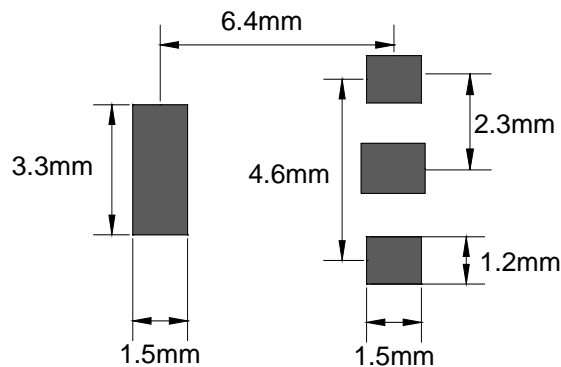

Disclaimer

The information presented in this document is for reference only. GuangDong Youfeng Microelectronics Co.,Ltd. reserves the right to make changes without notice for the specification of the products displayed herein to improve reliability, function or design or otherwise. The product listed herein is designed to be used with ordinary electronic equipment or devices, and not designed to be used with equipment or devices which require high level of reliability and the malfunction of with would directly endanger human life (such as medical instruments, transportation equipment, aerospace machinery, nuclear-reactor controllers, fuel controllers and other safety devices),YFW or anyone on its behalf, assumes no responsibility or liability for any damages resulting from such improper use of sale. This publication supersedes & replaces all information previously supplied. For additional information, please visit our website <https://www.yfwdiode.com>, or consult YFW sales office for further assistance.