

**650V N-Channel Enhancement Mode Power IGBT**

**MAIN CHARACTERISTICS**

<b>I<sub>c</sub> @TC=100°C</b>	60A
<b>V<sub>CE</sub></b>	650V
<b>VCE(sat)-typ</b>	1.8V

**FEATURES**

- ◆ Trench and field-stop technology
- ◆ Easy parallel switching capability

**APPLICATIONS**

- ◆ Energy storage
- ◆ Solar string inverter
- ◆ Uninterruptible power supplies

**MECHANICAL DATA**

- ◆ Case: Molded plastic
- ◆ Mounting Position: Any
- ◆ Molded Plastic: UL Flammability Classification Rating 94V-0
- ◆ Lead free in compliance with EU RoHS 2011/65/EU directive
- ◆ Solder bath temperature 275°C maximum,10s per JESD 22-B106

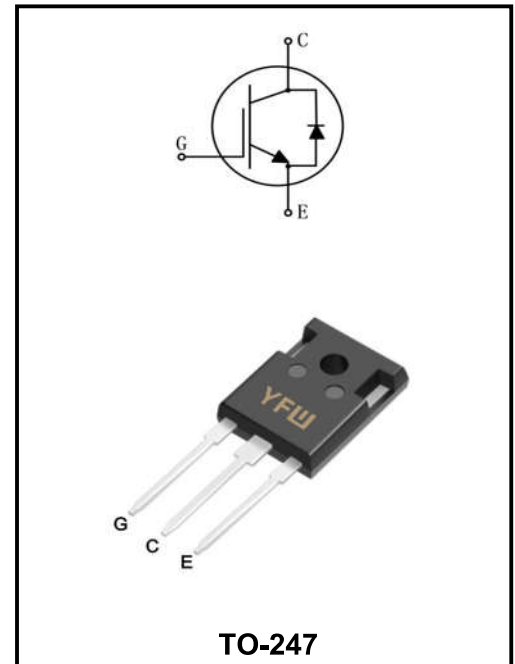

**Maximum Ratings**

Characteristics	Symbol	Value	Unit
Collector-emitter voltage	<b>V<sub>CEs</sub></b>	650	<b>V</b>
Gate-emitter voltage	<b>V<sub>GES</sub></b>	±20	<b>V</b>
Continuous collector current (TC=25°C)	<b>I<sub>c</sub></b>	120	<b>A</b>
Continuous collector current (TC=100°C)		60	<b>A</b>
Pulsed collector current, tp limited by Tvjmax	<b>I<sub>CM</sub></b>	240	<b>A</b>
Diode continuous forward current (TC=100°C)	<b>I<sub>F</sub></b>	60	<b>A</b>
Diode maximum current, tp limited by Tvjmax	<b>I<sub>FM</sub></b>	240	<b>A</b>
Power dissipation (TC=25°C)	<b>P<sub>tot</sub></b>	312	<b>W</b>
Power dissipation (TC=100°C)		156	<b>W</b>
Operating junction temperature range	<b>T<sub>vj</sub></b>	-40 to +175	<b>°C</b>
Storage temperature range	<b>T<sub>stg</sub></b>	-40 to +150	<b>°C</b>

**Thermal characteristics**

Characteristics	Symbol	Values		Unit
		Typ	Max.	
Thermal resistance, junction to case for IGBT	$R_{th(j-c)}$	-	0.48	K/ W
Thermal resistance, junction to case for Diode	$R_{th(j-c)}$	-	0.7	K/ W
Thermal resistance, junction to ambient	$R_{th(j-a)}$	-	40	K/ W

**Note1:Pulse test: 300  $\mu$ s pulse width, 2 % duty cycle**
**Electrical characteristics of IGBT at  $T_{vj}=25^{\circ}\text{C}$  unless otherwise specified**

Characteristics	Test Condition	Symbol	Min	Typ	Max	Unit	
Collector-emitter breakdown voltage	$V_{GE}=0V, I_c=250\mu A$	$B_{V_{CES}}$	650	-	-	V	
Collector-emitter leakage current	$V_{CE}=650V, V_{GE}=0V$	$I_{CES}$	-	-	50	$\mu A$	
Gate leakage current, forward	$V_{GE}=\pm 20V, V_{CE}=0V$	$I_{GES}$	-	-	$\pm 100$	nA	
Gate-emitter threshold voltage	$V_{GE}=V_{CE}, I_c=1mA$	$V_{GE(th)}$	4.7	5	5.3	V	
Collector-emitter saturation voltage	$V_{GE}=15V, I_c=60A$	$V_{CE(sat)}$	-	1.8	-	V	
	$V_{GE}=15V, I_c=60A, T_{vj}=175^{\circ}\text{C}$		-	2.5	-	V	
Input capacitance	$V_{CE}=30V$ $V_{GE}=0V$ $f=1MHz$	$C_{ies}$	-	3860	-	pF	
Output capacitance		$C_{oes}$	-	170	-	pF	
Reverse transfer capacitance		$C_{res}$	-	30	-	pF	
Total gate charge	$V_{CC}=520V, V_{GE}=15V, I_c=60A$	$Q_g$	-	120	-	nC	
Turn-on delay time	$V_{CC}=400V$ $V_{GE}=15V$ $I_c=60A$ $R_G=10\Omega$ Inductive load	$t_d(on)$	-	44	-	ns	
Rise time		$t_r$	-	100	-	ns	
Turn-off delay time		$t_d(off)$	-	166	-	ns	
Fall time		$t_f$	-	75	-	ns	
Turn-on energy		$E_{on}$	-	2.3	-	mJ	
Turn-off energy		$E_{off}$	-	1.3	-	mJ	
Total switching energy		$E_{ts}$	-	3.6	-	mJ	
Turn-on delay time		$V_{CC}=400V$ $V_{GE}=15V$ $I_c=60A$ $R_G=10\Omega$ Inductive load $T_{vj}=175^{\circ}\text{C}$	$t_d(on)$	-	45	-	ns
Rise time			$t_r$	-	105	-	ns
Turn-off delay time			$t_d(off)$	-	180	-	ns
Fall time	$t_f$		-	76	-	ns	
Turn-on energy	$E_{on}$		-	3.6	-	mJ	
Turn-off energy	$E_{off}$		-	1.6	-	mJ	
Total switching energy	$E_{ts}$		-	5.2	-	mJ	
Diode forward voltage	$I_F=60A$		$V_F$	-	1.7	-	V
	$I_F=60A, T_{vj}=175^{\circ}\text{C}$	-		1.4	-	V	
Diode reverse recovery time	$V_R=400V$ $I_F=60A$ $diF/dt=-450A/\mu s$	$t_{rr}$	-	78	-	ns	
Diode peak reverse recovery current		$I_{rrm}$	-	14	-	A	
Diode reverse recovery charge		$Q_{rr}$	-	600	-	nC	
Diode reverse recovery time		$t_{rr}$	-	155	-	ns	
Diode peak reverse recovery current	$V_R=400V$ $I_F=60A$ $diF/dt=-450A/\mu s, T_{vj}=175^{\circ}\text{C}$	$I_{rrm}$	-	25	-	A	
Diode reverse recovery charge		$Q_{rr}$	-	2300	-	nC	

**RATINGS AND CHARACTERISTIC CURVES**

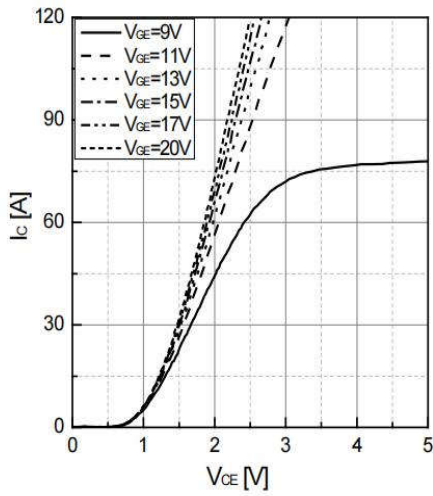

Fig 1. Typical output characteristic ( $T_{vj}=25^{\circ}\text{C}$ )

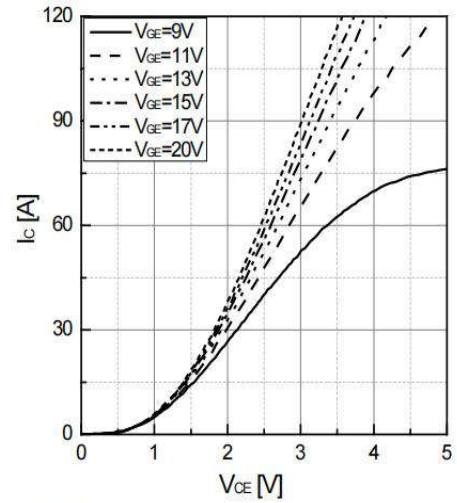

Fig 2. Typical output characteristic ( $T_{vj}=175^{\circ}\text{C}$ )

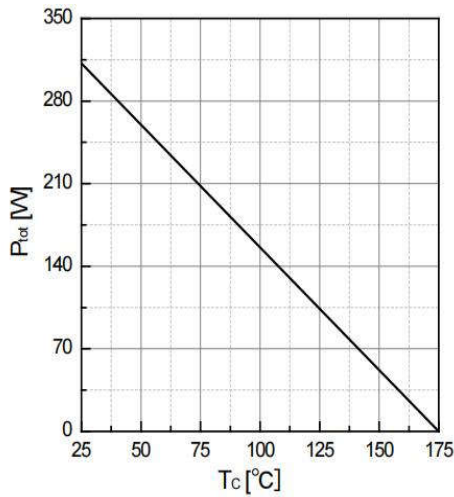

Fig 3. Power dissipation as a function of  $T_c$

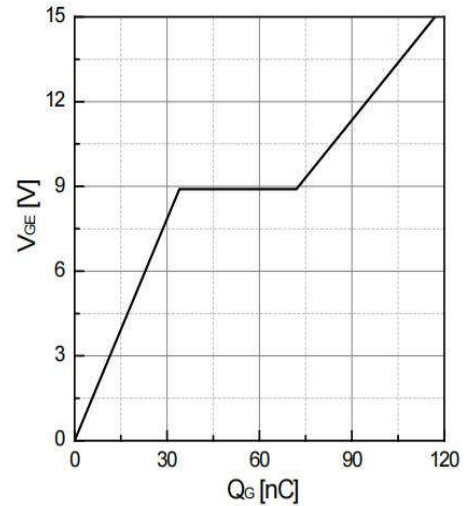

Fig 4. Typical Gate charge

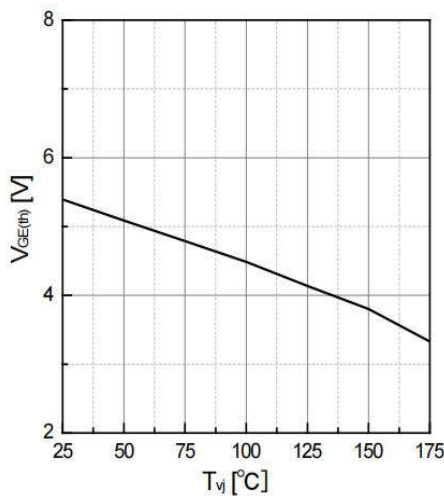

Fig 5. Typical  $V_{GE(th)}$  as a function of  $T_{vj}$   
( $I_c=1\text{mA}$ )

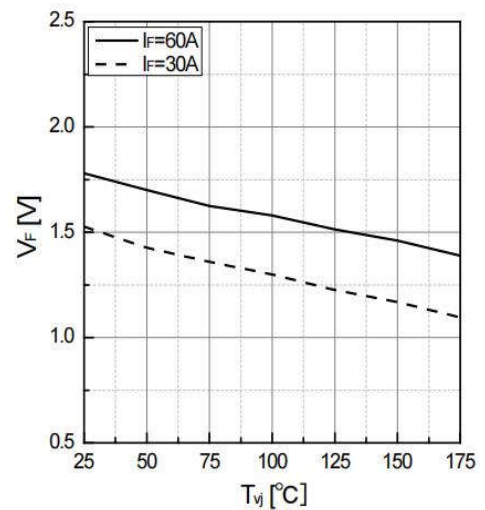

Fig 6. Typical  $V_F$  as a function of  $T_{vj}$

**RATINGS AND CHARACTERISTIC CURVES**

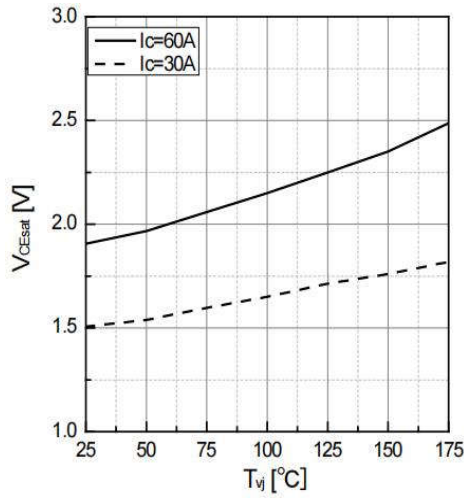

Fig 7. Typical  $V_{CEsat}$  as a function of  $T_{vj}$

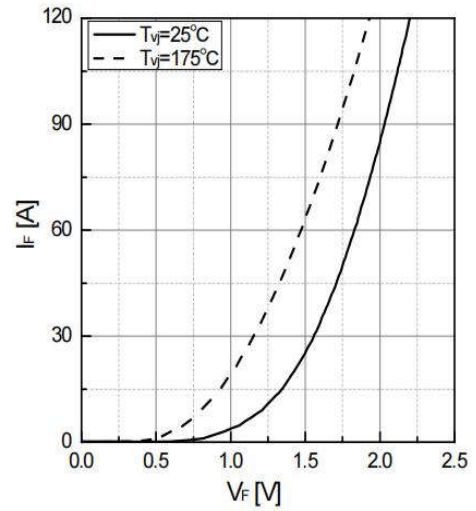

Fig 8. Typical  $I_F$  as a function of  $V_F$

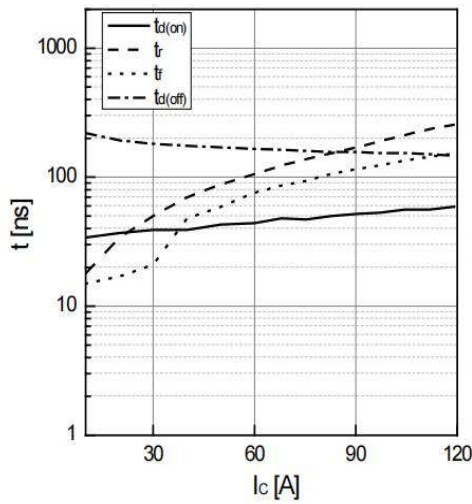

Fig 9. Typical switching time as a function of  $I_c$

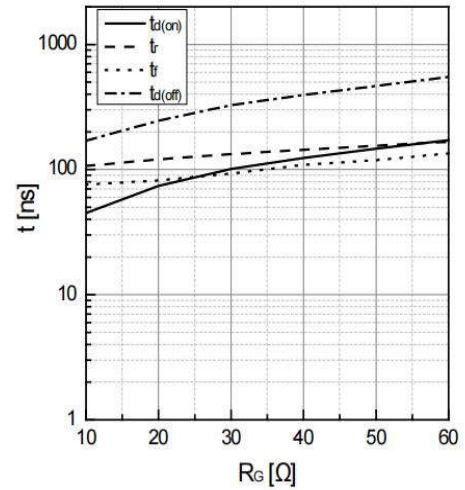

Fig 10. Typical switching times as a function of  $R_G$

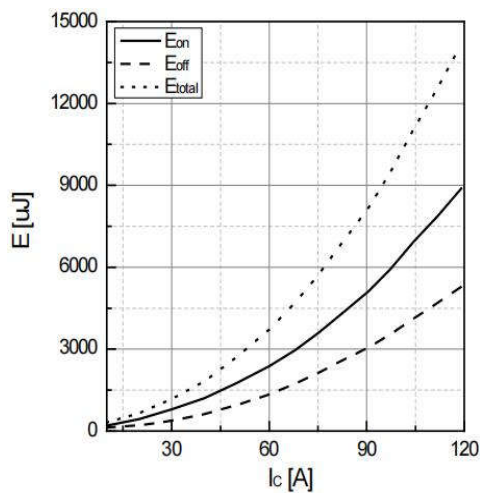

Fig 11. Typical switching energy losses as a function of  $I_c$

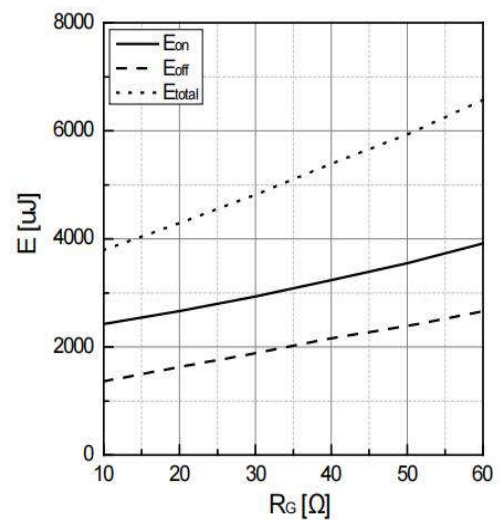

Fig 12. Typical switching energy losses as a function of  $R_G$

**RATINGS AND CHARACTERISTIC CURVES**

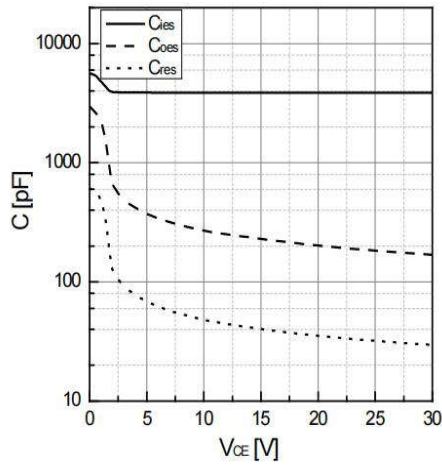

Fig 13. Typical capacitance as a function of  $V_{CE}$   
( $f=1\text{Mhz}$ ,  $V_{GE}=0\text{V}$ )

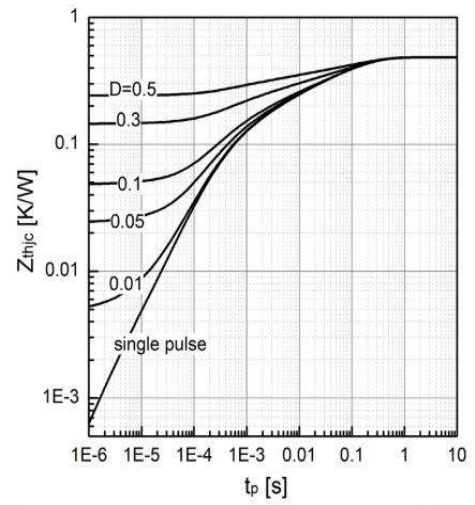
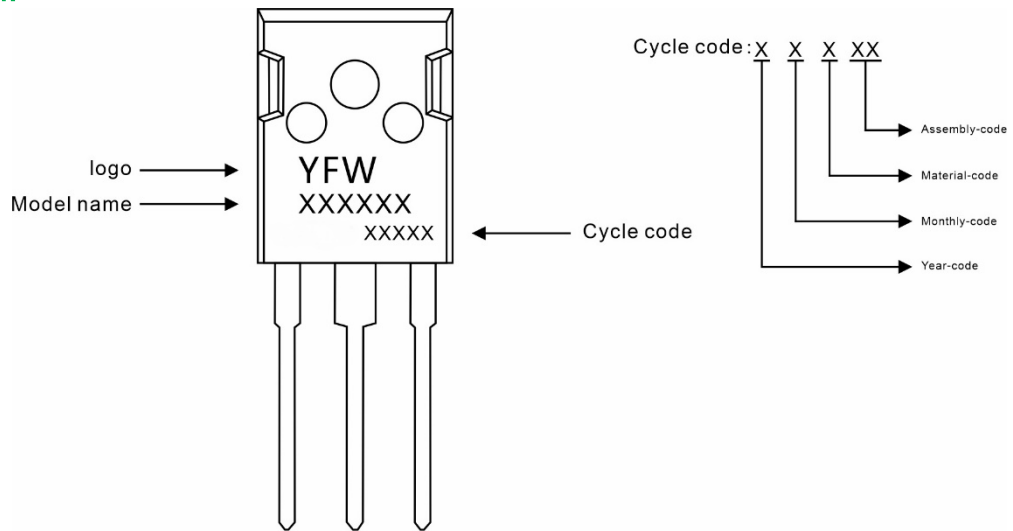

Fig 14. Transient thermal impedance of IGBT

**Marking Diagram**



**Ordering information**

Model name	Package	Unit Weight	Base Quantity	Packing Quantity
YFWG60T65AP	TO-247	0.209oz(5.93g)	30pcs/tube	600PCS/Box 2400PCS/Carton

**Package Dimensions**

**TO-247**

Symbol	Dimensions in mm		Dimensions in Inch	
	Min.	Max.	Min.	Max.
A	4.90	5.10	0.193	0.201
A1	1.90	2.10	0.075	0.083
A2	2.29	2.54	0.090	0.100
b	1.00	1.40	0.039	0.055
b1	2.00	2.20	0.079	0.087
b2	3.00	3.20	0.118	0.126
c	0.50	0.70	0.020	0.028
D	15.75	16.05	0.620	0.632
E	20.20	20.80	0.795	0.819
e	5.45 (BSC)		0.215 (BSC)	
e1	10.90 (BSC)		0.429 (BSC)	
F	6.05	6.25	0.238	0.246
F1	5.80	6.00	0.228	0.236
L	20.10	20.40	0.791	0.803
L1	4.05	4.35	0.159	0.171
Φ	3.50	3.70	0.138	0.146

## Disclaimer

The information presented in this document is for reference only. Guangdong Youfeng Microelectronics Co.,Ltd. reserves the right to make changes without notice for the specification of the products displayed herein to improve reliability, function or design or otherwise. The product listed herein is designed to be used with ordinary electronic equipment or devices, and not designed to be used with equipment or devices which require high level of reliability and the malfunction of which would directly endanger human life (such as medical instruments, transportation equipment, aerospace machinery, nuclear-reactor controllers, fuel controllers and other safety devices), YFW or anyone on its behalf, assumes no responsibility or liability for any damages resulting from such improper use of sale. This publication supersedes & replaces all information previously supplied. For additional information, please visit our website <https://www.yfwdiode.com>, or consult YFW sales office for further assistance.