

**-40V P-CHANNEL ENHANCEMENT MODE MOSFET**

**MAIN CHARACTERISTICS**

<b>I<sub>D</sub></b>	-40A
<b>V<sub>DSS</sub></b>	-40V
<b>R<sub>DS(on)-typ(@V<sub>GS</sub>=-10V)</sub></b>	< 18mΩ ( <b>Type:15 mΩ</b> )

**Application**

- ◆ Battery protection
- ◆ Load switch
- ◆ Uninterruptible power supply

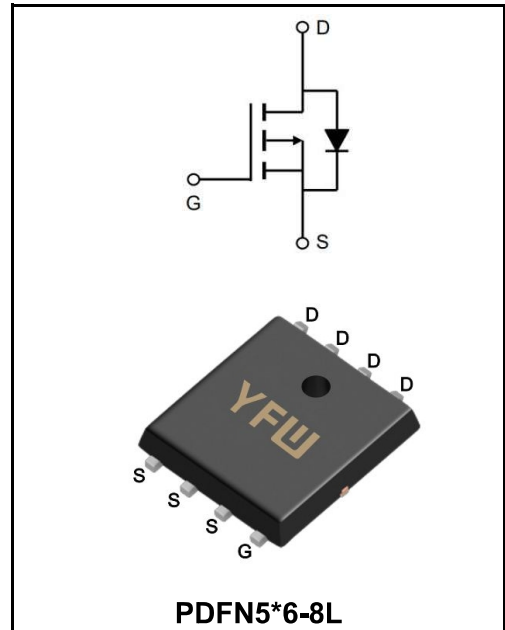

**Maximum Ratings at T<sub>c</sub>=25°C unless otherwise specified**

Characteristics	Symbols	Value	Units
Drain-Source Voltage	<b>V<sub>DS</sub></b>	-40	<b>V</b>
Gate - Source Voltage	<b>V<sub>GS</sub></b>	±20	<b>V</b>
Continuous Drain Current, V <sub>GS</sub> @ -10V <sup>1</sup> @T <sub>C</sub> =25°C	<b>I<sub>D</sub></b>	-40	<b>A</b>
Continuous Drain Current, V <sub>GS</sub> @ -10V <sup>1</sup> @T <sub>C</sub> =100°C	<b>I<sub>D</sub></b>	-23	<b>A</b>
Pulsed Drain Current <sup>2</sup>	<b>I<sub>DM</sub></b>	-120	<b>A</b>
Single Pulse Avalanche Energy <sup>3</sup>	<b>E<sub>AS</sub></b>	125	<b>mJ</b>
Total Power Dissipation <sup>4</sup> @T <sub>C</sub> =25°C	<b>P<sub>D</sub></b>	25	<b>W</b>
Total Power Dissipation <sup>4</sup> @T <sub>A</sub> =25°C	<b>P<sub>D</sub></b>	16	<b>W</b>
Storage Temperature Range	<b>T<sub>STG</sub></b>	-55 to +150	<b>°C</b>
Operating Junction Temperature Range	<b>T<sub>J</sub></b>	-55 to +150	<b>°C</b>
Thermal Resistance Junction-Ambient <sup>1</sup>	<b>R<sub>θJA</sub></b>	25	<b>°C/W</b>
Thermal Resistance Junction-Case <sup>1</sup>	<b>R<sub>θJC</sub></b>	5	<b>°C/W</b>

**Maximum Ratings at Tc=25°C unless otherwise specified**

Characteristics	Test Condition	Symbols	Min	Typ	Max	Units
Drain-Source Breakdown Voltage	$V_{GS}=0V, I_D=-250\mu A$	$BV_{DSS}$	-40	-44	-	V
$BV_{DSS}$ Temperature Coefficient	Reference to 25°C, $I_D=-1mA$	$\Delta BV_{DSS}/\Delta T_J$	-	-0.023	-	V/°C
Static Drain-Source On-Resistance <sup>2</sup>	$V_{GS}=-10V, I_D=-30A$	$R_{DS(ON)}$	-	15	18	mΩ
	$V_{GS}=-4.5V, I_D=-20A$		-	18	25	
Gate -Threshold Voltage	$V_{DS}=V_{GS}, I_D=-250\mu A$	$V_{GS(th)}$	-1.0	-1.6	-2.5	V
$V_{GS(th)}$ Temperature Coefficient		$\Delta V_{GS(th)}$	-	4.74	-	mV/°C
Drain-Source Leakage Current	$V_{DS}=-40V, V_{GS}=0V, T_J=25^\circ C$	$I_{DSS}$	-	-	1	μA
	$V_{DS}=-40V, V_{GS}=0V, T_J=55^\circ C$		-	-	5	
Gate -Source Leakage Current	$V_{GS}=\pm 20V, V_{DS}=0V$	$I_{GSS}$	-	-	±100	nA
Total Gate Charge(-4.5V)	$V_{DS}=-20V$ $V_{GS}=-4.5V$ $I_D=-12A$	$Q_g$	-	25	-	nC
Gate-Source Charge		$Q_{GS}$	-	11	-	
Gate-Drain Charge		$Q_{gd}$	-	9.5	-	
Turn-on delay time	$V_{DD}=-15V$ $R_L=15\Omega$ $I_D=-1A$ $V_{GEN}=-10V$ $R_G=6\Omega$	$t_{d(on)}$	-	48	-	ns
Rise Time		$T_r$	-	24	-	
Turn-Off Delay Time		$t_{d(OFF)}$	-	88	-	
Fall Time		$t_f$	-	9.6	-	
Input Capacitance	$V_{DS}=-20V$ $V_{GS}=0V$ $f=1MHz$	$C_{iss}$	-	2760	-	pF
Output Capacitance		$C_{oss}$	-	260	-	
Reverse Transfer Capacitance		$C_{rss}$	-	85	-	
Continuous Source Current <sup>1,5</sup>	$V_G=V_D=0V, \text{Force Current}$	$I_S$	-	-	-40	A
Pulsed Source Current <sup>2,5</sup>		$I_{SM}$	-	-	-90	A
Diode Forward Voltage <sup>2</sup>	$V_{GS}=0V, I_S=-1A, T_J=25^\circ C$	$V_{SD}$	-	-	-1.3	V

Note :

- 1、The data tested by surface mounted on a 1 inch2 FR-4 board with 2OZ copper.
- 2、The data tested by pulsed , pulse width  $\cong 300\mu s$  , duty cycle  $\cong 2\%$
- 3、The EAS data shows Max. rating . The test condition is  $V_{DD}=-32V, V_{GS}=-10V, L=0.1mH, I_{AS}=-30A$
- 4、The power dissipation is limited by 150°C junction temperature
- 5、The data is theoretically the same as ID and IDM , in real applications , should be limited by total power dissipation.

Ratings and Characteristic Curves

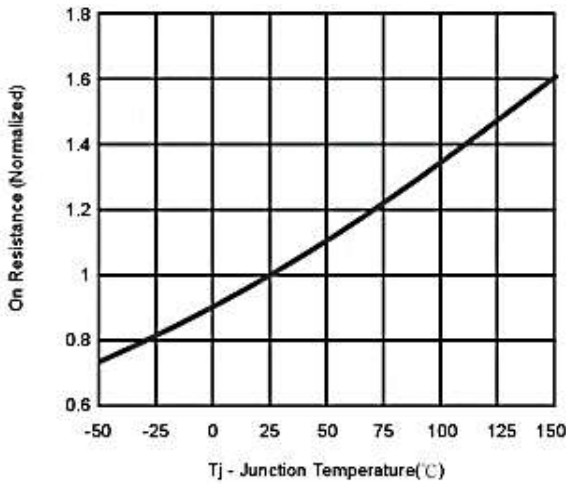

Fig.1 On Resistance Vs Junction Temperature

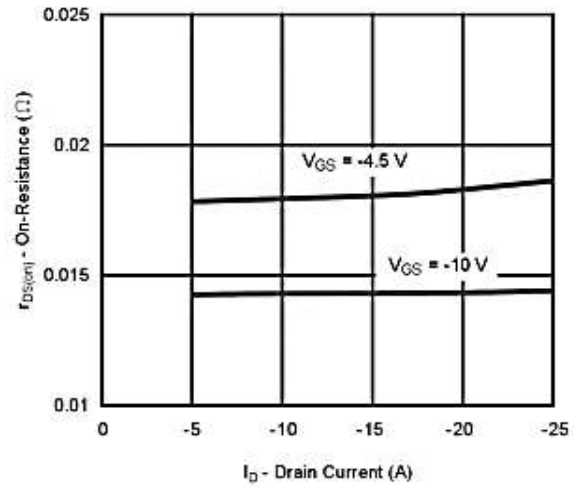

Fig.2 On-Resistance Vs. Drain Current

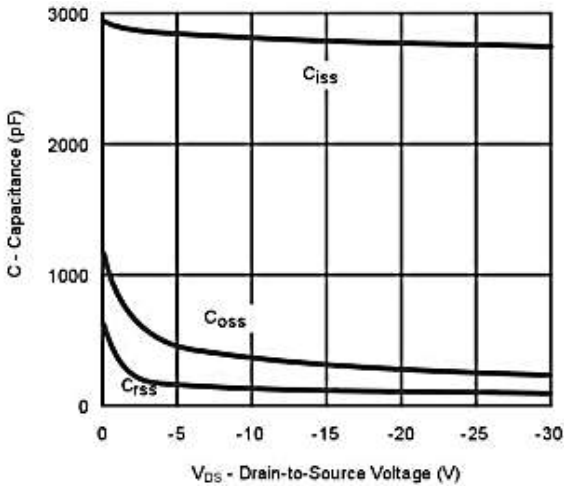

Fig.3 Capacitance

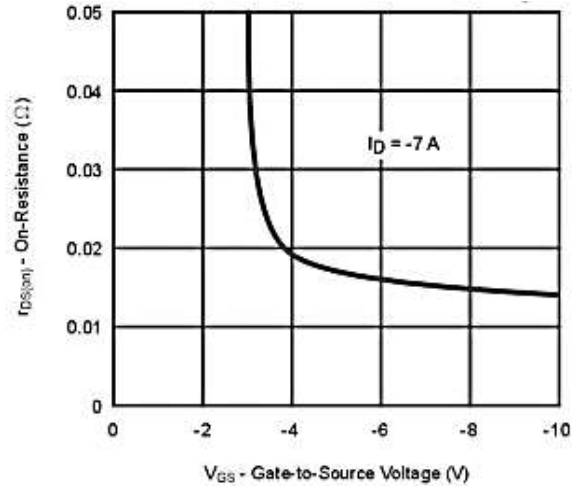

Fig.4 On-Resistance Vs. Gate-to-Source Voltage

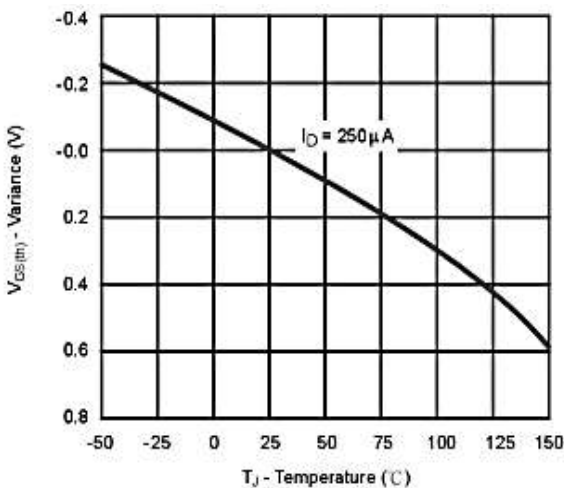

Fig.5 Threshold Voltage

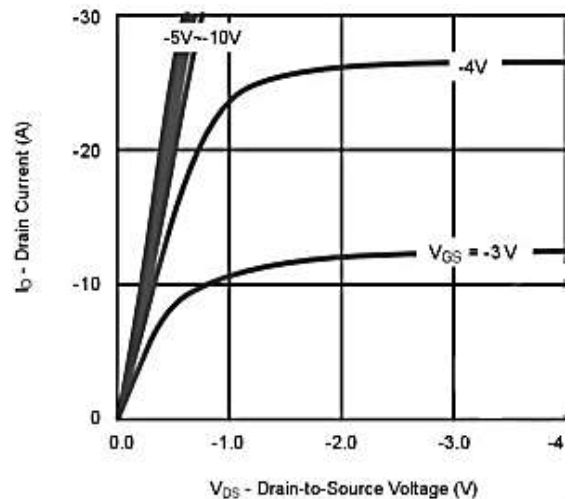

Fig.6 On-Region Characteristics

Ratings and Characteristic Curves

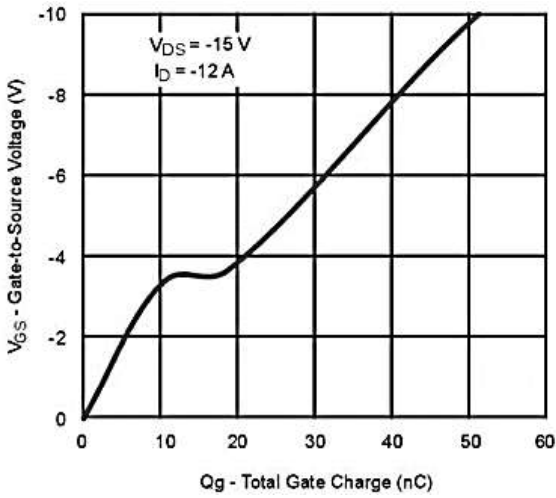

Fig.7 Gate Charge

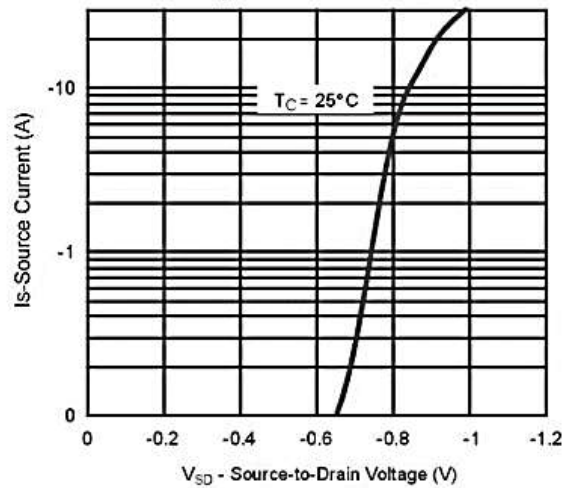

Fig.8 Body-diode Characteristic

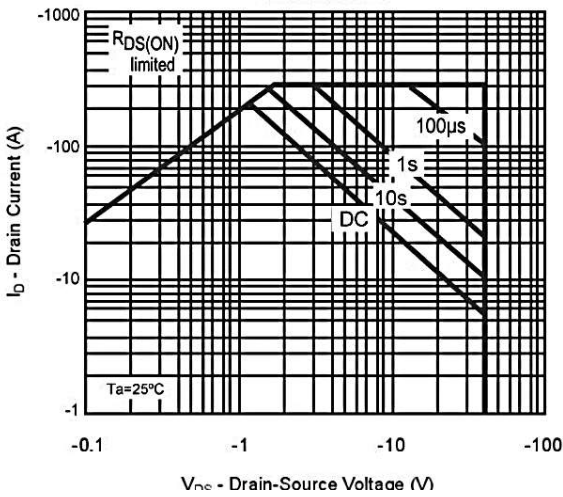

Fig.9 Safe Operating Area

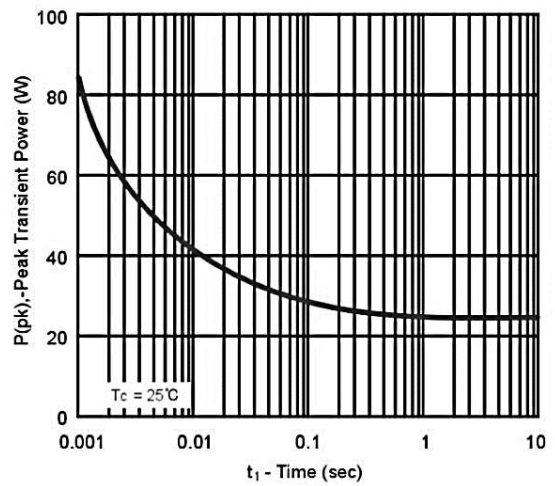

Fig.10 Single Pulse Maximum Power Dissipation

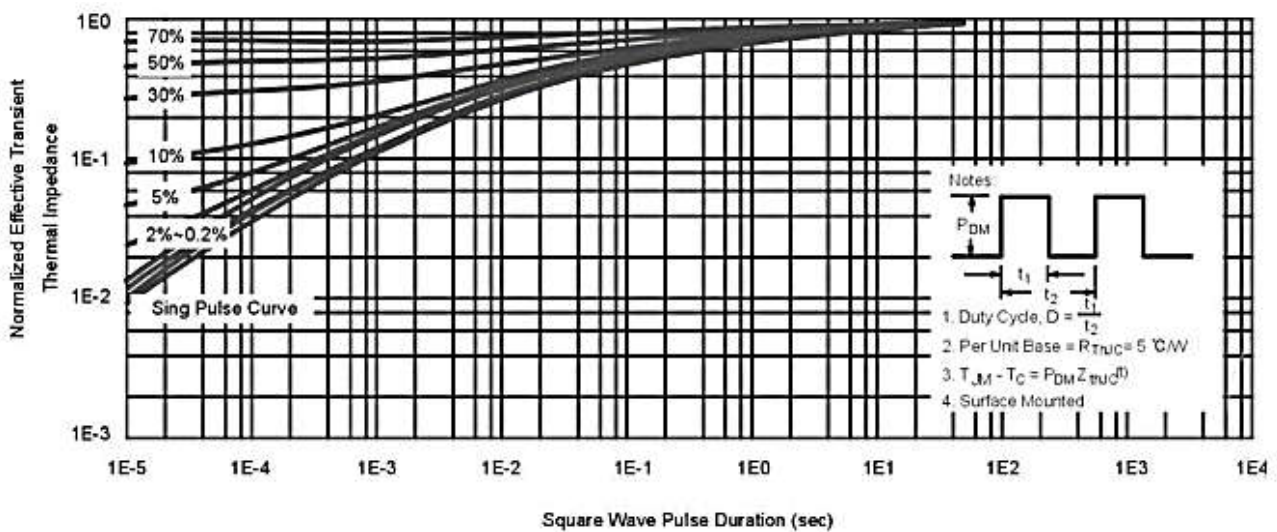
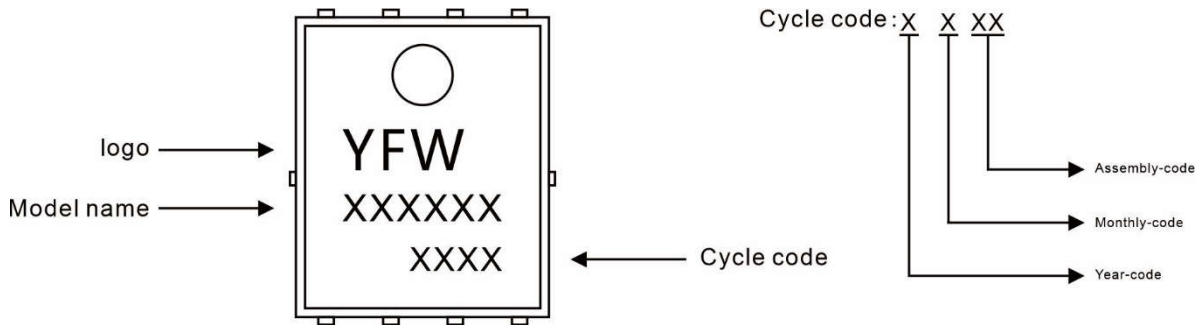

Fig.11 Normalized Maximum Transient Thermal Impedance

**Marking Diagram**



**Ordering information**

Model name	Package	Unit Weight	Base Quantity	Packing Quantity
YFW40P04NF	PDFN5*6-8L	0.0032oz(0.093g)	5000pcs/reel	10000pcs/box 50000pcs/Carton

**Package Dimensions**

PDFN5\*6-8L

Dim	Millimeter		mil	
	Min.	Max.	Min.	Max.
A	0.9	1.2	35	45
A2	0.204	0.304	8	12
b	0.4ref.		16ref.	
b1	0.2	0.4	8	16
D	5.0	5.3	197	209
D1	4.84	5.24	191	206
E	5.95	6.35	234	250
E1	3.275	3.675	129	145
E2	5.69	6.09	224	232
e	1.27typ.		50typ.	
K	1.29typ.		51typ.	
L	0.585	0.785	23	27
L1	0.7typ.		28typ.	

## Disclaimer

The information presented in this document is for reference only. Guangdong Youfeng Microelectronics Co.,Ltd. reserves the right to make changes without notice for the specification of the products displayed herein to improve reliability, function or design or otherwise. The product listed herein is designed to be used with ordinary electronic equipment or devices, and not designed to be used with equipment or devices which require high level of reliability and the malfunction of which would directly endanger human life (such as medical instruments, transportation equipment, aerospace machinery, nuclear-reactor controllers, fuel controllers and other safety devices), YFW or anyone on its behalf, assumes no responsibility or liability for any damages resulting from such improper use of sale. This publication supersedes & replaces all information previously supplied. For additional information, please visit our website <https://www.yfwdiode.com>, or consult YFW sales office for further assistance.