

**4.0A 4Quadrants TRIACs**

**Product Summary**

Symbol	Value	Unit
$I_{T(RMS)}$	4.0	A
$V_{DRM}$ $V_{RRM}$	600/800	V
$V_{TM}$	1.55	V

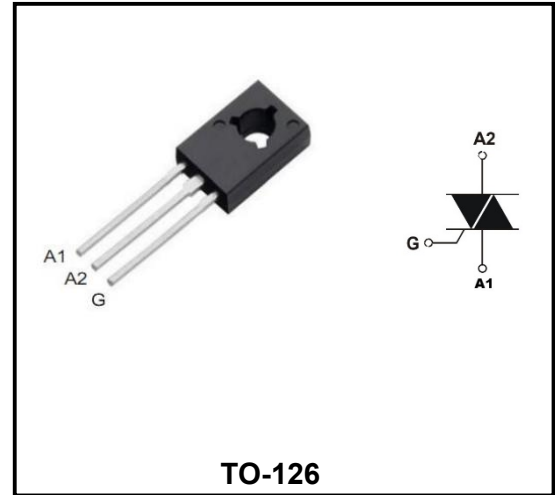

**Features**

With high ability to withstand the shock loading of large current, With high commutation performances, 4 quadrants products especially recommended for use on inductive load.

**Application**

Washing machine, vacuums, massager, solid state relay, AC Motor speed regulation and so on.

**Order Information**

Part Number	Package	Marking	Packing	Packing Quantity
BT134	TO-126	BT134 XXXX	Box	500PCS/Box

**Absolute maximum ratings (Ta=25°C unless otherwise noted)**

Parameter	Symbol	Value	Unit	
Repetitive peak off-state voltage	$V_{DRM}$	600/800	V	
Repetitive peak reverse voltage	$V_{RRM}$	600/800	V	
RMS on-state current	$I_{T(RMS)}$	4	A	
Non repetitive surge peak on-state current (full cycle, F=50Hz)	$I_{TSM}$	25	A	
I <sup>2</sup> t value for fusing (tp=10ms)	I <sup>2</sup> t	3.1	A <sup>2</sup> s	
Critical rate of rise of on-state current (I <sub>G</sub> = 2 x I <sub>GT</sub> )	$di_T/dt$	I - II - III	50	A/us
		IV	10	A/us
Peak gate current	$I_{GM}$	2	A	
Average gate power dissipation	$P_G$ (AV)	0.5	W	
Junction Temperature	$T_J$	-40~+125	°C	
Storage Temperature	$T_{STG}$	-40 ~+150	°C	

**Electrical characteristics (TA=25°C, unless otherwise noted)**

Parameter	Symbol	Test Condition	Value		Unit	
			Min	Max		
Gate trigger current	$I_{GT}$	$V_D=12V$ $I_T=0.1A$ $T_j=25^\circ C$	I-II-III	-	10	<b>mA</b>
			IV	-	25	
Gate trigger voltage	$V_{GT}$	I-II-III-IV	-	1.3	<b>V</b>	
Gate non-trigger voltage	$V_{GD}$	$V_D = V_{DRM}$ $T_j=125^\circ C$	0.2	-	<b>V</b>	
latching current	$I_L$	$V_D = 12V$ $I_{GT}=0.1A$ $T_j=25^\circ C$	I-III-IV	-	15	<b>mA</b>
			II	-	20	
Holding current	$I_H$	I-II-III-IV	-	15	<b>mA</b>	
Critical-rate of rise of commutation voltage	$dV_D/dt$	$V_D=2/3V_{DRM}$ Gate Open $T_j=125^\circ C$	20	-	<b>V/us</b>	

**STATIC CHARACTERISTICS**

Forward "on" voltage	$V_{TM}$	$I_{TM} = 6A$ $t_p=380us$	-	1.55	<b>V</b>	
Repetitive Peak Off-State Current	$I_{DRM}$	$V_D=V_{DRM}$ $V_R=V_{RRM}$	$T_j=25^\circ C$	-	5	<b>uA</b>
Repetitive Peak Reverse Current	$I_{RRM}$		$T_j=125^\circ C$	-	500	<b>uA</b>

**THERMAL RESISTANCES**

Thermal resistance	$R_{th(j-c)}$	Junction to case(AC)	TYP.	3	<b>°C/W</b>
	$R_{th(j-a)}$	Junction to ambient	TYP.	100	<b>°C/W</b>

**Ordering Information**

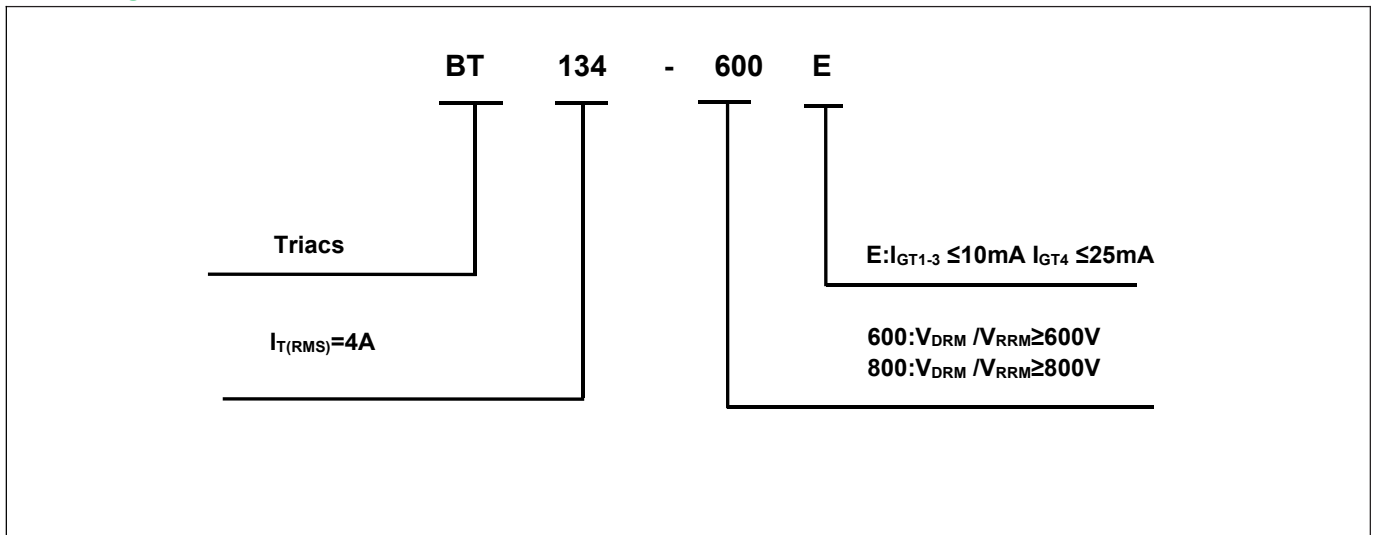

Typical Characteristics

FIG.1: Maximum power dissipation versus RMS on-state current (full cycle)

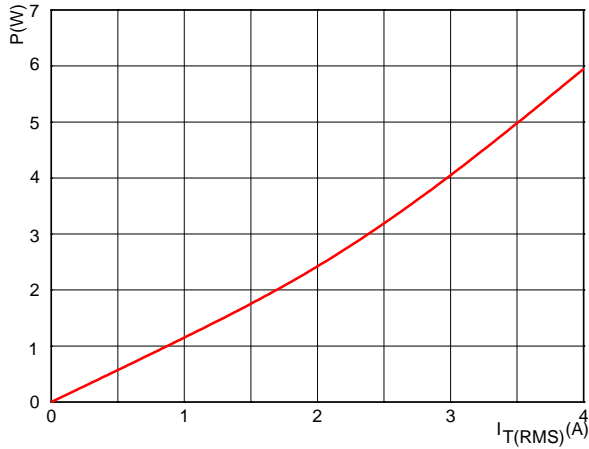

FIG.2: RMS on-state current versus case temperature (full cycle)

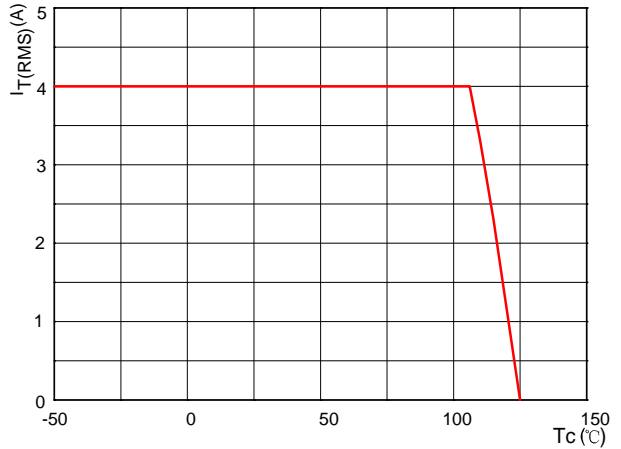

FIG.3: Surge peak on-state current versus number of cycles

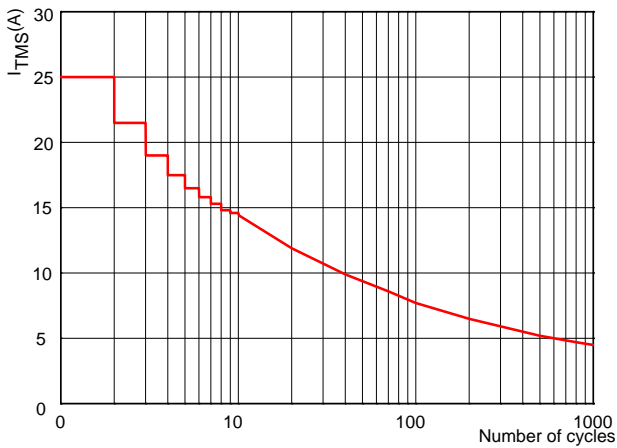

FIG.4: On-state characteristics (maximum values)

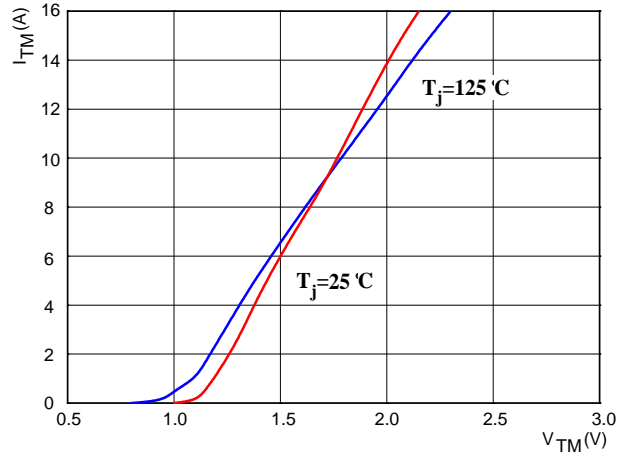

FIG.5: Non-repetitive surge peak on-state current for a sinusoidal pulse with width  $t_p < 10\text{ms}$

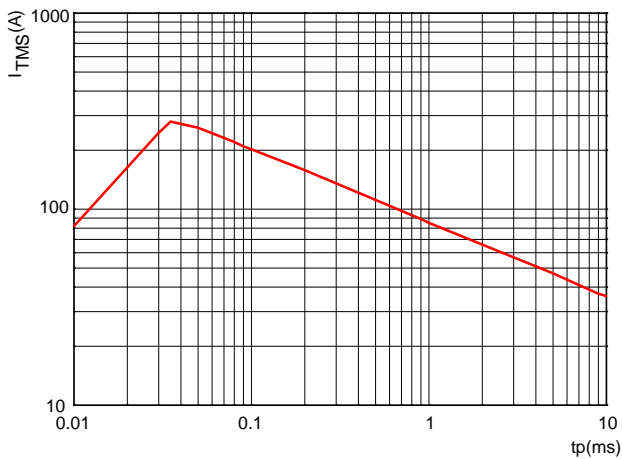
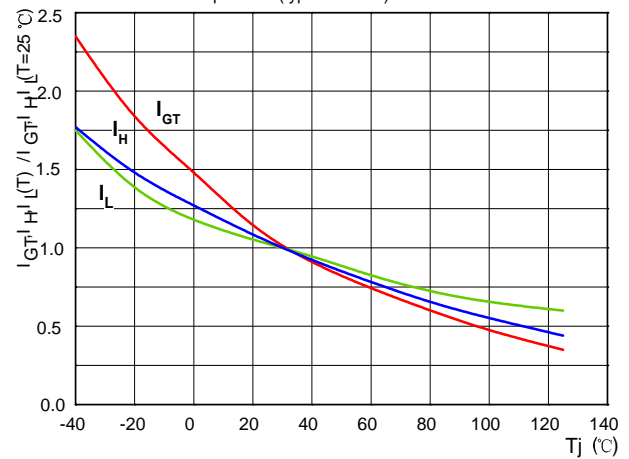

FIG.6: Relative variations of gate trigger current, holding current and latching current versus junction temperature (typical values)



**Ordering information**

Package	Packing Description	Base Quantity
TO-126	Bulk	500pcs/Bag

**Package Dimensions**

**TO-126**

Symbol	Millimeter		Inches	
	Min.	Max.	Min.	Max.
A	2.40	2.80	0.094	0.110
A1	1.00	1.40	0.039	0.055
b	0.66	0.86	0.026	0.034
b1	1.17	1.37	0.046	0.054
c	0.40	0.60	0.016	0.024
D	7.30	7.70	0.287	0.303
E	10.60	11.00	0.417	0.433
e	2.25	2.33	0.089	0.092
e1	4.50	4.66	0.177	0.183
L	14.00	15.00	0.551	0.591
L1	1.90	2.50	0.075	0.098
Φ	3.10	3.30	0.122	0.130

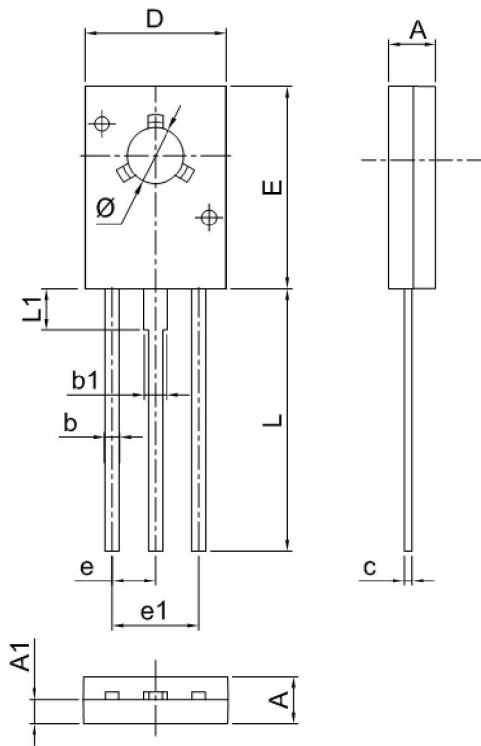

## Disclaimer

The information presented in this document is for reference only. GuangDong Youfeng Microelectronics Co.,Ltd. reserves the right to make changes without notice for the specification of the products displayed herein to improve reliability, function or design or otherwise. The product listed herein is designed to be used with ordinary electronic equipment or devices, and not designed to be used with equipment or devices which require high level of reliability and the malfunction of which would directly endanger human life (such as medical instruments, transportation equipment, aerospace machinery, nuclear-reactor controllers, fuel controllers and other safety devices), YFU or anyone on its behalf, assumes no responsibility or liability for any damages resulting from such improper use of sale. This publication supersedes & replaces all information previously supplied. For additional information, please visit our website <https://www.yfwdiode.com>, or consult YFU sales office for further assistance.