

**12A Standard SCRs**

**Product Summary**

Symbol	Value	Unit
$I_{T(RMS)}$	12	A
$V_{DRM} V_{RRM}$	600/800	V
$V_{TM}$	1.55	V

**Features**

With high ability to withstand the shock loading of large current, Provide high dv/dt rate with strong resistance to electromagnetic interference.

**Application**

Power charger, T-tools, massager, solid state relay, AC Motor speed regulation and so on.

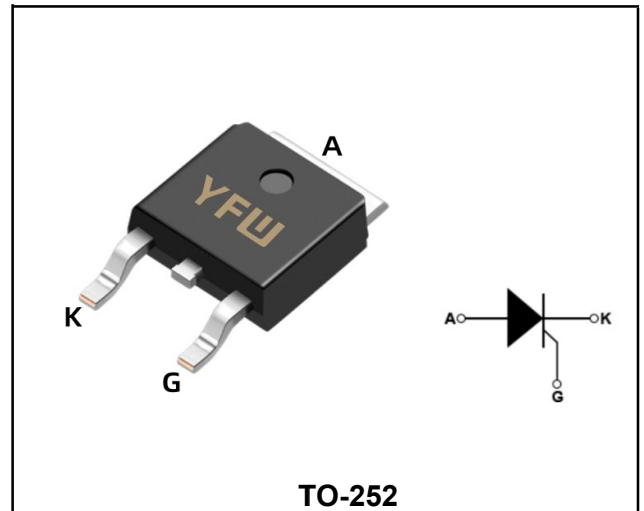

**Absolute maximum ratings (Ta=25°C unless otherwise noted)**

Parameter	Symbol	Value	Unit
Repetitive peak off-state voltage	$V_{DRM}$	600/800	V
Repetitive peak reverse voltage	$V_{RRM}$	600/800	V
RMS on-state current	$I_{T(RMS)}$	12	A
Non repetitive surge peak on-state current (full cycle, F=50Hz)	$I_{TSM}$	95	A
$I^2t$ value for fusing (tp=10ms)	$I^2t$	45	A <sup>2</sup> s
Critical rate of rise of on-state current ( $I_G = 2 \times I_{GT}$ )	$di_T/dt$	50	A/ $\mu$ s
Peak gate current	$I_{GM}$	4	A
Average gate power dissipation	$P_G (AV)$	1	W
Junction Temperature	$T_J$	-40~+125	°C
Storage Temperature	$T_{STG}$	-40 ~+150	°C

**Electrical characteristics (TA=25°C, unless otherwise noted)**

Parameter	Symbol	Test Condition	Value		Unit
			Min	Max	
Gate trigger current	$I_{GT}$	$V_D = 12V R_L = 140\Omega$	-	10	<b>mA</b>
Gate trigger voltage	$V_{GT}$		-	1.3	<b>V</b>
Gate non-trigger voltage	$V_{GD}$	$V_D = V_{DRM} T_j = 125^\circ C$	0.2	-	<b>V</b>
latching current	$I_L$	$I_G = 1.2I_{GT}$	-	50	<b>mA</b>
Holding current	$I_H$	$I_T = 50mA$	-	40	<b>mA</b>
Critical-rate of rise of commutation voltage	$dV_D/dt$	$V_D = 2/3V_{DRM}$ Gate Open $T_j = 125^\circ C$	200	-	<b>V/<math>\mu s</math></b>

**STATIC CHARACTERISTICS**

Forward "on" voltage	$V_{TM}$	$I_{TM} = 16A$ $t_p = 380\mu s$	-	1.55	<b>V</b>	
Repetitive Peak Off-State Current	$I_{DRM}$	$V_D = V_{DRM} V_R = V_{RRM}$	$T_j = 25^\circ C$	-	5	<b><math>\mu A</math></b>
Repetitive Peak Reverse Current	$I_{RRM}$		$T_j = 125^\circ C$	-	2	<b>mA</b>

**THERMAL RESISTANCES**

Thermal resistance	$R_{th(j-c)}$	Junction to case	TYP.	1.3	<b><math>^\circ C/W</math></b>
	$R_{th(j-a)}$	Junction to ambient	TYP.	70	<b><math>^\circ C/W</math></b>

**Ordering Information**

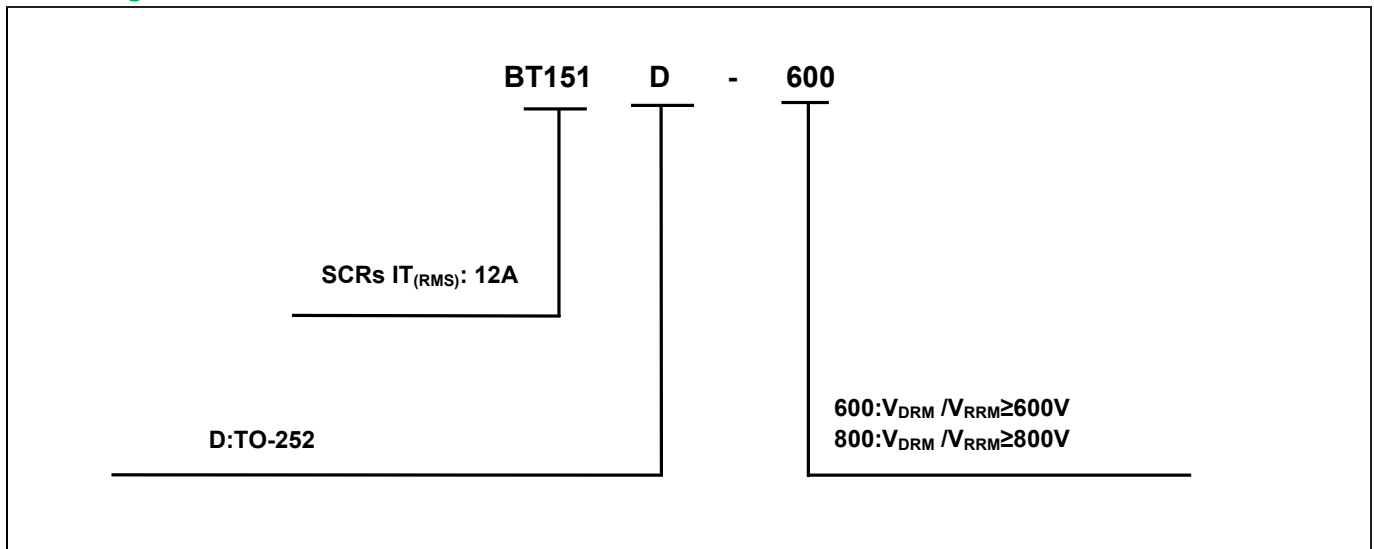

Typical Characteristics

FIG.1: Maximum power dissipation versus RMS on-state current (full cycle)

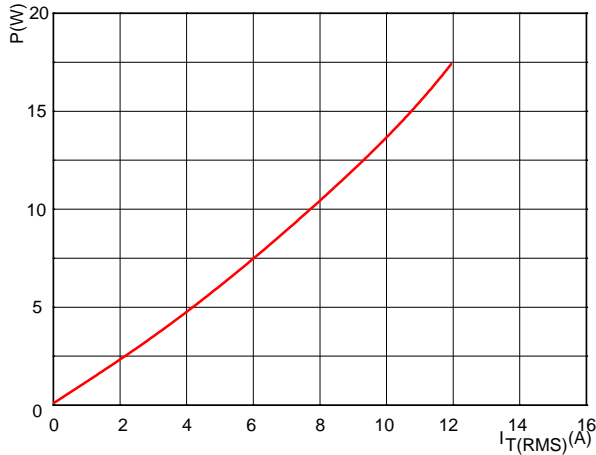

FIG.2: RMS on-state current versus case temperature (full cycle)

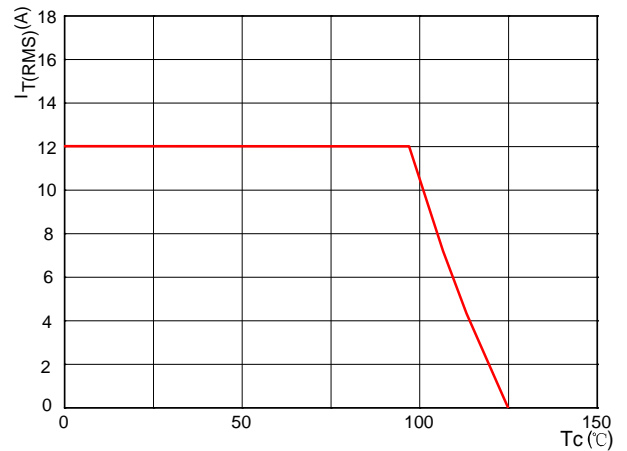

FIG.3: Surge peak on-state current versus number of cycles

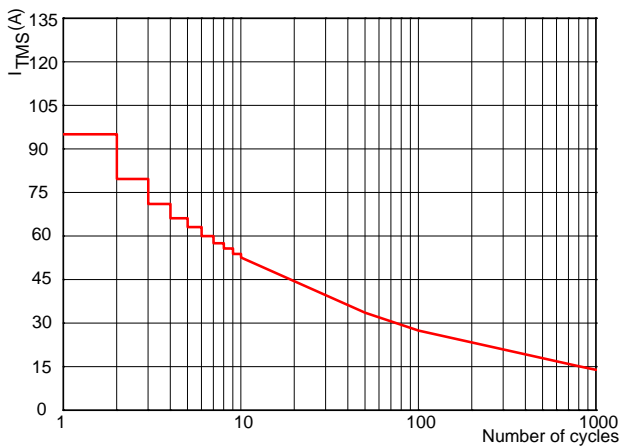

FIG.4: On-state characteristics (maximum values)

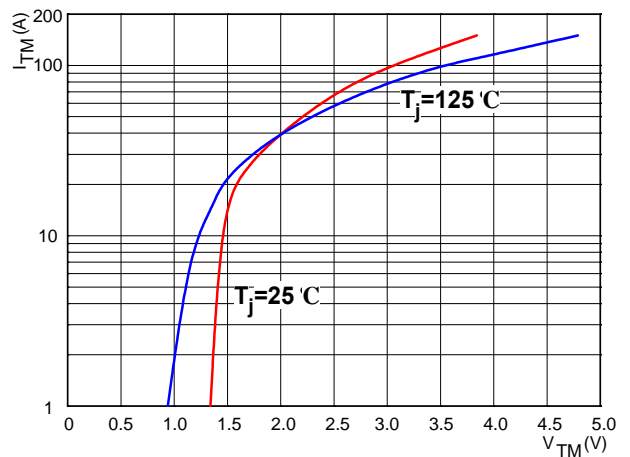

FIG.5: Non-repetitive surge peak on-state current for a sinusoidal pulse with width  $t_p < 10\text{ms}$

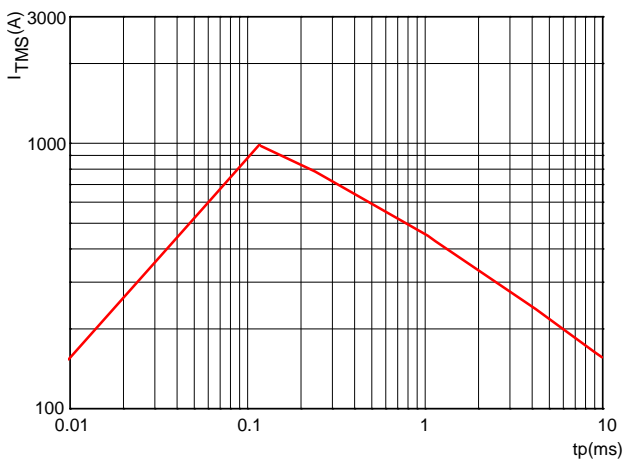
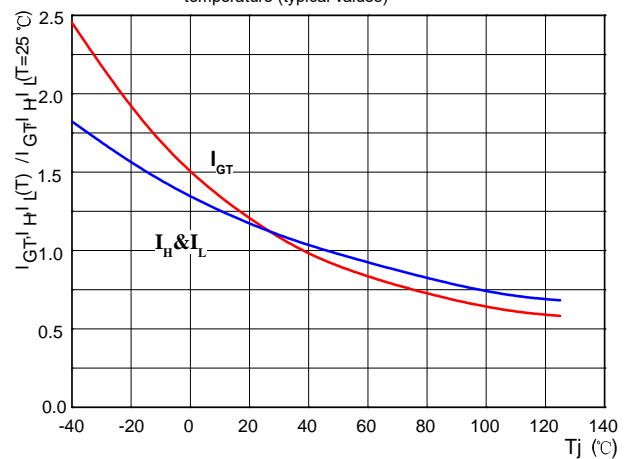
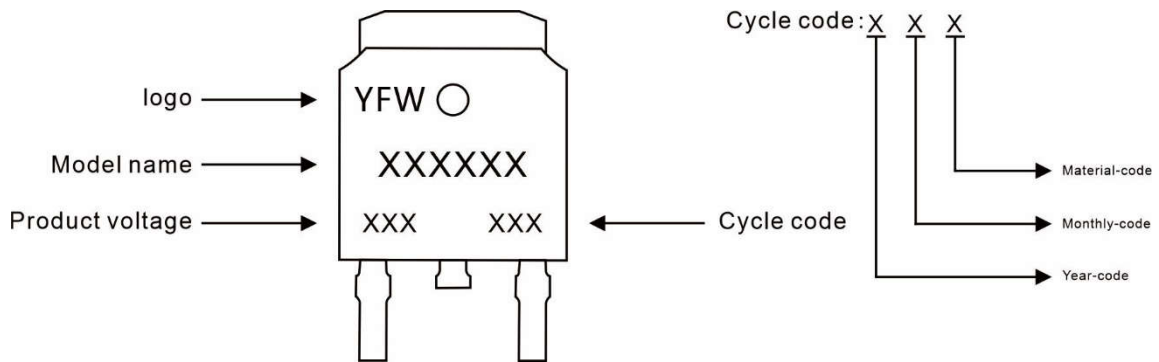

FIG.6: Relative variations of gate trigger current, holding current and latching current versus junction temperature (typical values)



Typical Characteristics

**Marking Diagram**



**Ordering information**

Model name	Package	Unit Weight	Base Quantity	Packing Quantity
BT151D	TO-252	0.011oz(0.32g)	2500pcs/reel	5000pcs/box 25000pcs/Carton

**Package Dimensions**

**TO-252**

Dim	Millimeter		Inches	
	Min.	Max.	Min.	Max.
A	2.20	2.50	0.087	0.098
A1	0.00	0.12	0.000	0.005
A2	2.20	2.40	0.087	0.094
B	1.20	1.60	0.047	0.063
b	0.50	0.70	0.020	0.028
b1	0.70	0.90	0.028	0.035
c	0.40	0.60	0.016	0.024
c1	0.40	0.60	0.016	0.024
D	6.35	6.65	0.250	0.262
D1	5.20	5.40	0.205	0.213
E	5.40	5.70	0.213	0.224
e	2.20	2.40	0.087	0.094
e1	4.40	4.80	0.173	0.189
L	10.00	11.00	0.393	0.433
L1	2.70	3.10	0.106	0.122
L2	1.40	1.80	0.055	0.071
L3	0.90	1.50	0.035	0.059

## Disclaimer

The information presented in this document is for reference only. GuangDong Youfeng Microelectronics Co.,Ltd. reserves the right to make changes without notice for the specification of the products displayed herein to improve reliability, function or design or otherwise. The product listed herein is designed to be used with ordinary electronic equipment or devices, and not designed to be used with equipment or devices which require high level of reliability and the malfunction of with would directly endanger human life (such as medical instruments, transportation equipment, aerospace machinery, nuclear-reactor controllers, fuel controllers and other safety devices),YFW or anyone on its behalf, assumes no responsibility or liability for any damages resulting from such improper use of sale. This publication supersedes & replaces all information previously supplied. For additional information, please visit our website <https://www.yfwdiode.com>, or consult YFW sales office for further assistance.