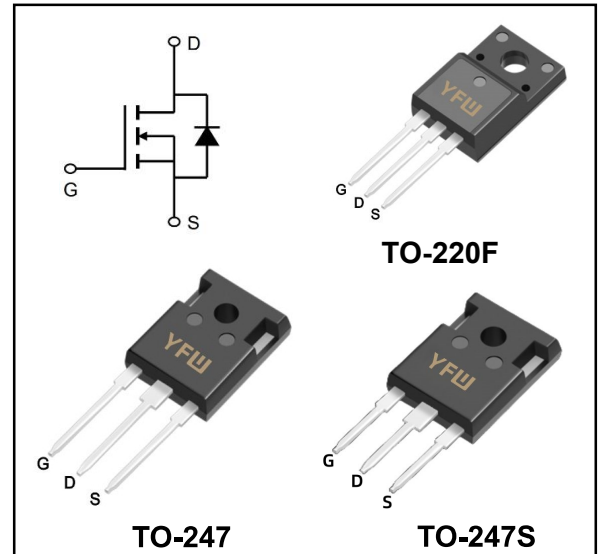

600V N-CHANNEL ENHANCEMENT MODE MOSFET
MAIN CHARACTERISTICS

I_D	16A
V_{DSS}	600V
$R_{DS(on)-typ}(@V_{GS}=10V)$	<0.48Ω (Type:0.4Ω)

Features

- ◆Fast Switching
- ◆Low ON Resistance
- ◆Low Gate Charge
- ◆100% Single Pulse avalanche energy Test
- ◆LeadfreeincomplywithEURoHS2011/65/EUdirectives

Mechanical Data

- ◆Case: Molded plastic
- ◆Mounting Position: Any
- ◆Molded Plastic: UL Flammability Classification Rating 94V-0
- ◆Solder bath temperature 275°C maximum, 10s per JESD22-106

Maximum Ratings at Tc=25°C unless otherwise specified

Characteristics	Symbols	Value		Units
		220F	247/247S	
Drain-Source Voltage	V_{DS}	600		V
Gate-Source Voltage	V_{GS}	±30		V
Continue Drain Current	I_D	16		A
-Continuous (TC = 100°C)		10		
Power Dissipation	P_D	70	180	W
-Derate above 25°C		0.51	1.25	
Single Pulse Avalanche Energy (Note2)	E_{AS}	800		mJ
Avalanche Current (Note 1)	I_{AR}	16		A
Repetitive Avalanche Energy (Note 1)	E_{AS}	28		mJ
Operating Temperature Range	T_J	150		°C
Storage Temperature Range	T_{STG}	-55 to +150		°C
Thermal Resistance, Junction to Case	$R_{\theta JC}$	1.95	0.7	°C/W
Thermal Resistance, Junction to Ambient	$R_{\theta JA}$	62.5	62.5	°C/W

Maximum Ratings at Tc=25°C unless otherwise specified

Characteristics	Test Condition	Symbols	Min	Typ	Max	Units
Drain-Source Breakdown Voltage	$V_{GS} = 0\text{ V}, I_D = 250\ \mu\text{A}$	BV_{DSS}	600	-	-	V
Breakdown Voltage Temperature Coefficient	$I_D = 250\ \mu\text{A}$ (Referenced to 25°C)	$\frac{\Delta BV_{DSS}}{\Delta T_J}$	-	0.5	-	V/°C
Drain-Source Leakage Current	$V_{DS} = 600\text{ V}, V_{GS} = 0\text{ V}$	I_{DSS}	-	-	1	uA
	$V_{DS} = 480\text{ V}, T_c = 125^\circ\text{C}$		-	-	10	
Gate Leakage Current	$V_{GS} = \pm 30\text{ V}, V_{DS} = 0\text{ V}$	I_{GSS}	-	-	±100	nA
Gate-Source Threshold Voltage	$V_{DS} = V_{GS}, I_D = 250\ \mu\text{A}$	$V_{GS(th)}$	2	-	4	V
Drain-Source On-State Resistance	$V_{GS} = 10\text{ V}, I_D = 8\text{ A}$	$R_{DS(on)}$	-	0.4	0.48	Ω
Forward Transconductance	$V_{DS} = 15\text{ V}, I_D = 8\text{ A}$	g_{fs}	-	15	-	S
Input Capacitance	$V_{GS} = 0\text{ V}, V_{DS} = 25\text{ V},$ $f = 1\text{ MHz}$	C_{iss}	-	2250	-	pF
Output Capacitance		C_{oss}	-	208	-	
Reverse Transfer Capacitance		C_{rss}	-	17	-	
Turn-on Delay Time	$I_D = 16\text{ A}, V_{DD} = 300\text{ V},$ $R_G = 10\ \Omega$ (Note3,4)	$t_{d(ON)}$	-	30	-	nS
Rise Time		t_r	-	70	-	
Turn-Off Delay Time		$t_{d(OFF)}$	-	145	-	
Fall Time		t_f	-	74	-	
Total Gate Charge	$I_D = 16\text{ A}, V_{DD} = 480\text{ V},$ $V_{GS} = 10\text{ V}$ (Note3,4)	Q_G	-	71	-	nC
Gate to Source Charge		Q_{GS}	-	15	-	
Gate to Drain Charge		Q_{GD}	-	22	-	

Source-Drain Diode Characteristics at Ta=25°C unless otherwise specified

Characteristics	Test Condition	Symbols	Min	Typ	Max	Units
Maximun Body-Diode Continuous Current		I_S	-	-	16	A
Maximun Body-Diode Pulsed Current		I_{SM}	-	-	64	A
Drain-Source Diode Forward Voltage	$I_{SD} = 16\text{ A}$	V_{SD}	-	-	1.4	V
Reverse Recovery Time	$I_{SD} = 16\text{ A}, V_{GS} = 0\text{ V},$ $di_F / dt = 100\text{ A}/\mu\text{s}$	t_{rr}	-	410	-	nS
Reverse Recovery Charge		Q_{rr}	-	3.5	-	uC

Note:

1. Repetitive Rating: Pulse width limited by maximum junction temperature.
2. $I_{AS} = 16\text{ A}, V_{DD} = 50\text{ V}, L = 6\text{ mH}, R_G = 25\ \Omega$, starting $T_J = 25^\circ\text{C}$.
3. ulse test: Pulse Width ≤300 μ s, Duty Cycle ≤2%.
4. Essentially Independent of Operating Temperature.

Ratings and Characteristic Curves

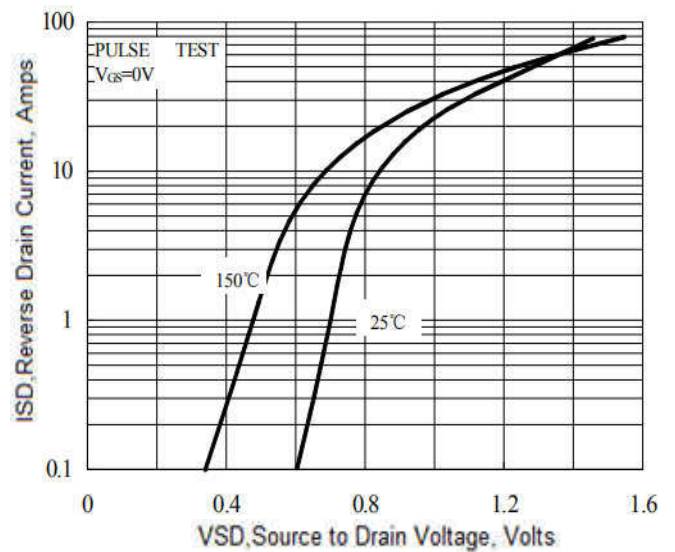
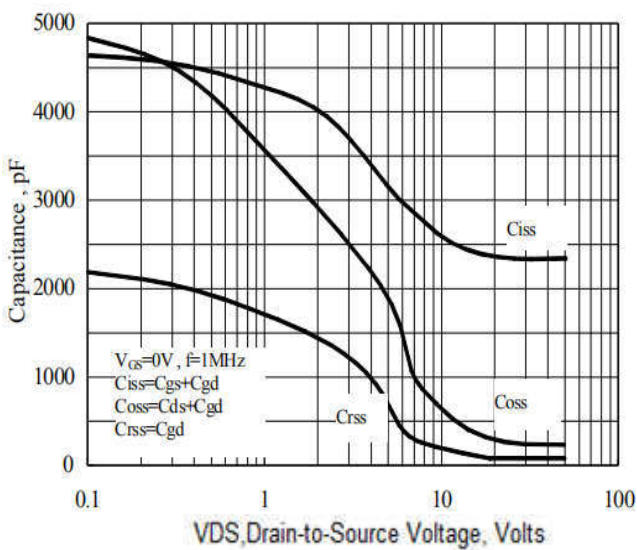
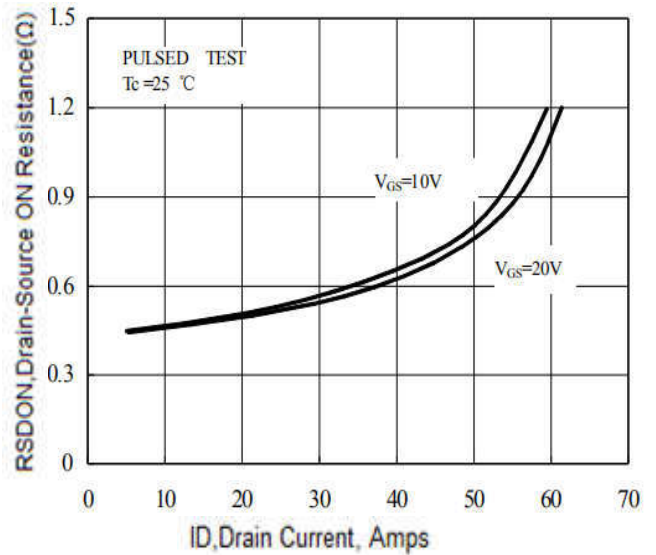
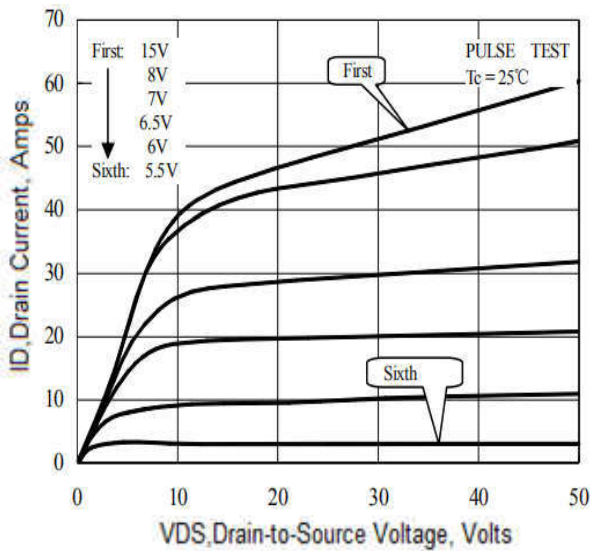
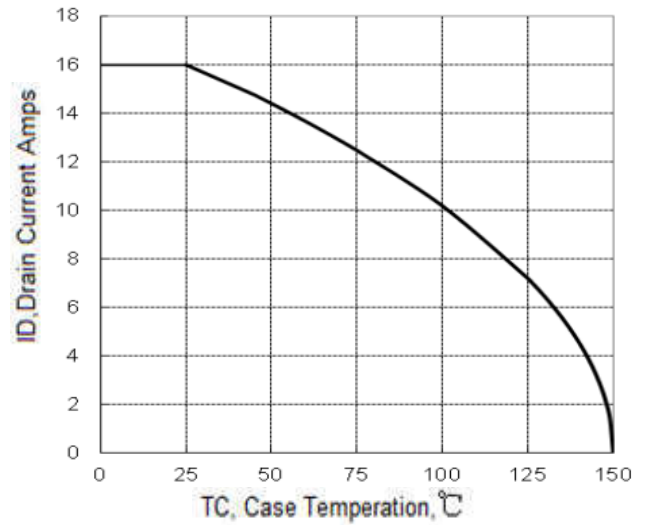
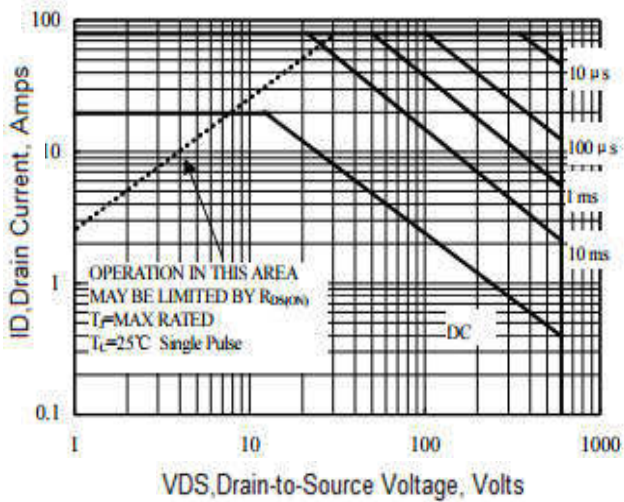

Marking Diagram

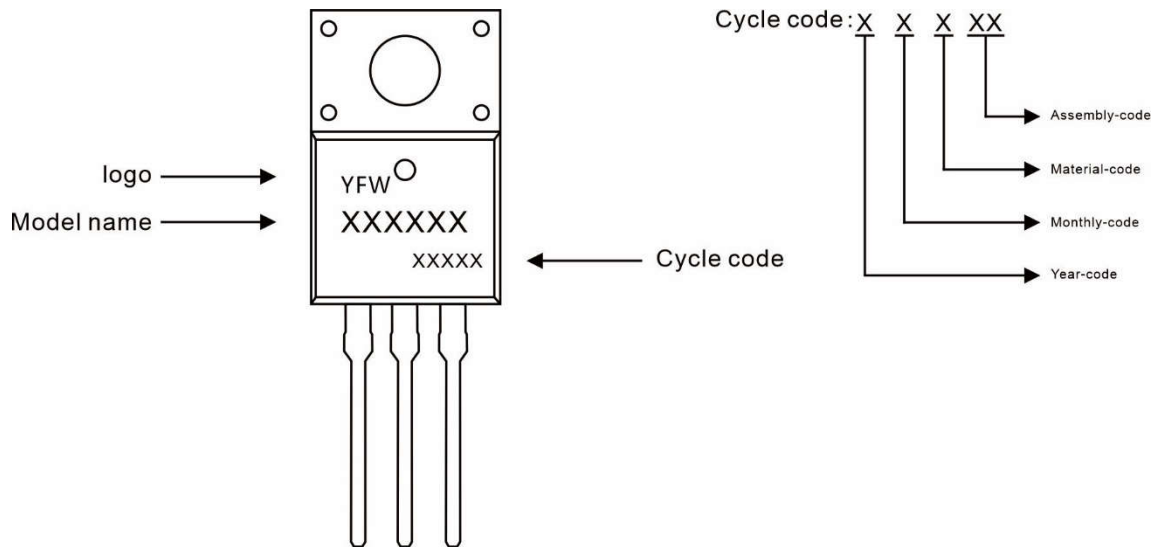

Ordering information

Model name	Package	Unit Weight	Base Quantity	Packing Quantity
YFW16N60AF	TO-220F	0.06oz(1.74g)	50pcs/tube	1000PCS/Box 5000PCS/Carton

Package Dimensions

TO-220F

Symbol	Millimeter		Inches	
	Min.	Max.	Min.	Max.
A	4.50	4.90	0.177	0.193
A1	2.34	2.74	0.092	0.108
A2	2.66	2.86	0.105	0.113
b	0.75	0.85	0.030	0.033
b1	1.24	1.44	0.049	0.057
c	0.40	0.60	0.016	0.024
D	10.00	10.32	0.394	0.406
E	15.75	16.05	0.620	0.632
e	2.44	2.64	0.096	0.104
e1	4.88	5.28	0.192	0.208
F	3.10	3.5	0.122	0.138
L	13.50	13.90	0.531	0.547
L1	2.90	3.30	0.114	0.130
Φ	3.10	3.30	0.122	0.130

Marking Diagram

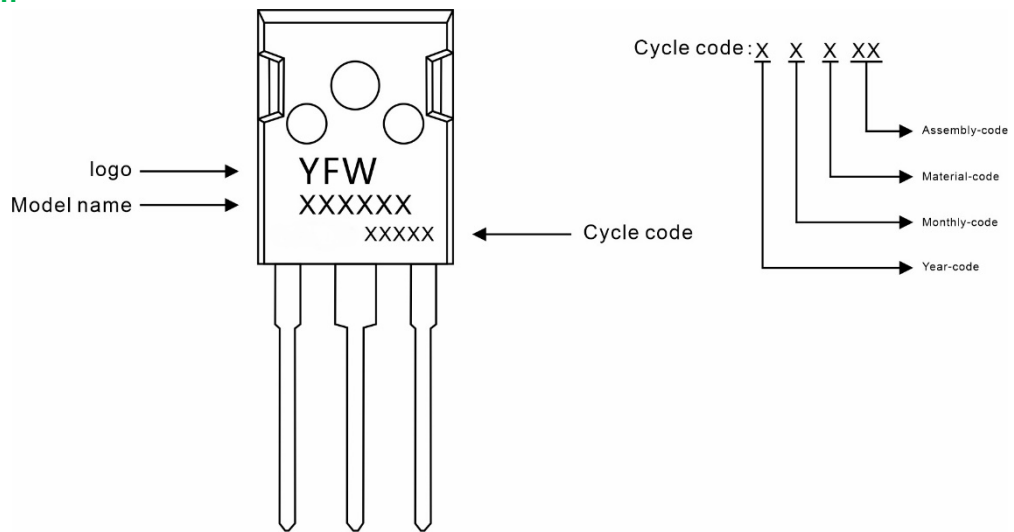

Ordering information

Model name	Package	Unit Weight	Base Quantity	Packing Quantity
YFW16N60AP	TO-247	0.209oz(5.93g)	30pcs/tube	600PCS/Box 2400PCS/Carton

Package Dimensions

TO-247

Symbol	Dimensions in mm		Dimensions in Inch	
	Min.	Max.	Min.	Max.
A	4.90	5.10	0.193	0.201
A1	1.90	2.10	0.075	0.083
A2	2.29	2.54	0.090	0.100
b	1.00	1.40	0.039	0.055
b1	2.00	2.20	0.079	0.087
b2	3.00	3.20	0.118	0.126
c	0.50	0.70	0.020	0.028
D	15.75	16.05	0.620	0.632
E	20.20	20.80	0.795	0.819
e	5.45 (BSC)		0.215 (BSC)	
e1	10.90 (BSC)		0.429 (BSC)	
F	6.05	6.25	0.238	0.246
F1	5.80	6.00	0.228	0.236
L	20.10	20.40	0.791	0.803
L1	4.05	4.35	0.159	0.171
Φ	3.50	3.70	0.138	0.146

Marking Diagram

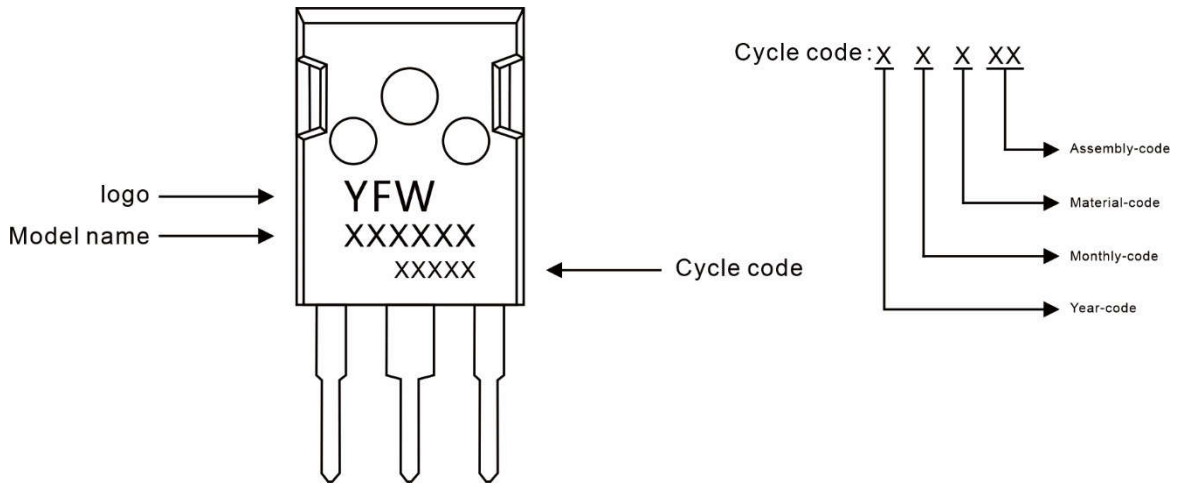

Ordering information

Model name	Package	Unit Weight	Base Quantity	Packing Quantity
YFW16N60APS	TO-247S	0.158oz(4.48g)	30pcs/tube	600PCS/Box 2400PCS/Carton

Package Dimensions

TO-247S

Symbol	Dimensions in mm		Dimensions in Inch	
	Min.	Max.	Min.	Max.
A	15.0	16.0	0.59	0.63
B	19.5	20.5	0.77	0.81
C	33.5	35.5	1.32	1.40
D	5.0	6.0	0.20	0.24
E	3.5	4.5	0.14	0.18
F	2.5	3.5	0.10	0.14
G	1.75	2.5	0.07	0.14
H	3.0	4.0	0.12	0.16
I	9.0	11.0	0.35	0.43
J	4.9	5.1	0.19	0.20
K	1.0	1.3	0.04	0.05
L	3.75	4.25	0.15	0.17
M	4.75	5.25	0.19	0.21
N	1.8	2.2	0.07	0.09
O	0.45	0.6	0.018	0.024
P	5.08		0.2	
Q	1.2	1.3	0.05	0.051

Disclaimer

The information presented in this document is for reference only. Guangdong Youfeng Microelectronics Co.,Ltd. reserves the right to make changes without notice for the specification of the products displayed herein to improve reliability, function or design or otherwise. The product listed herein is designed to be used with ordinary electronic equipment or devices, and not designed to be used with equipment or devices which require high level of reliability and the malfunction of which would directly endanger human life (such as medical instruments, transportation equipment, aerospace machinery, nuclear-reactor controllers, fuel controllers and other safety devices), YFW or anyone on its behalf, assumes no responsibility or liability for any damages resulting from such improper use of sale. This publication supersedes & replaces all information previously supplied. For additional information, please visit our website <https://www.yfwdiode.com>, or consult YFW sales office for further assistance.